



Transport
Canada

Transports
Canada

TP 14371E

Transport Canada

Aeronautical Information Manual (TC AIM)

AGA—AERODROME

MARCH 21, 2024

Canada 

TRANSPORT CANADA AERONAUTICAL INFORMATION MANUAL (TC AIM)
EXPLANATION OF CHANGES
EFFECTIVE—MARCH 21, 2024

NOTES:

1. Editorial and format changes were made throughout the TC AIM where necessary, and those that were deemed insignificant in nature were not included in the “Explanation of Changes.”
2. Effective March 31, 2016, licence differences with ICAO Annex 1 Standards and Recommended Practices, previously located in LRA 1.8 of the TC AIM, have been removed and can now be found in *AIP Canada* GEN 1.7.
3. The blue highlights in the manual represent the changes described in this section.

Table of Contents

AGA—AERODROMES

49

1.0	GENERAL INFORMATION	49
1.1	General	49
1.1.1	Aerodrome Authority	49
1.1.2	International Civil Aviation Organization (ICAO) Documents	49
1.1.3	Canadian Runway Friction Index (CRFI)	49
1.1.4	Contaminated Runway Operations	49
1.1.4.1	Canadian Civil Aerodromes	49
1.1.4.2	Department of National Defence Aerodromes	49
1.1.5	Wildlife Hazard	49
1.2	International Airports	49
1.2.1	International Civil Aviation Organization (ICAO) Definitions	50
1.3	Aerodrome Directory	50
1.4	Aeronautical Ground Lights	50
2.0	AERODROMES AND AIRPORTS	50
2.1	General	50
2.1.1	Registration	50
2.1.2	Certification	50
2.2	Use of Aerodromes, Airports, and Heliports	51
2.3	Airport/Heliport/Water Airport Certification	51
2.3.1	General	51
2.3.2	Applicability of Airport Certification	51
2.3.3	Transport Canada's Responsibilities	51
2.3.4	Operator's Responsibilities	51
2.3.5	Airport Certification Process	52
2.3.6	Regulatory References for Aerodrome Certification (Airport/Heliport/Water Airport)	52
2.4	Airport/Heliport/Water Airport Certificate	52
2.4.1	Issue	52
2.4.2	Airport Certificate Validity and Amendments	52
3.0	RUNWAY CHARACTERISTICS	52
3.1	Runway Length and Width	52
3.2	Runway Strip	52
3.3	Runway Safety Area	52
3.4	Runway End Safety Area (RESA)	52
3.5	Runway Threshold Displacement	53
3.6	Runway Turn Pad	53
3.7	Blast Pad	53
3.8	Stopway	53
3.9	Clearway	53
3.10	Declared Distances	53
3.11	Rapid-Exit Taxiways	53
3.12	Runway and Taxiway Bearing Strength	53
3.12.1	Pavement Load Rating Charts	54
3.13	Heliports	54
3.13.1	Final Approach and Take-Off Area (FATO)	54
3.13.2	Heliport Classification	54
3.13.3	Heliport Operational Limitations	54
4.0	OBSTACLE RESTRICTIONS	54
4.1	General	54
4.2	Obstacle Limitation Surfaces (OLS)	55
4.2.1	General	55
4.2.2	Heliports	55

4.3	Airport Zoning Regulations	55
4.3.1	General.....	55
4.3.2	Airports Where Zoning Regulations Are in Effect.....	55
5.0	MARKERS, MARKINGS, SIGNS, AND INDICATORS	55
5.1	Aircraft Take-off or Landing Area Boundary Markers	55
5.2	Air Taxiway Edge Markers	56
5.3	Seaplane Dock Markers	56
5.4	Runway Markings	57
5.4.1	Displaced Threshold Markings.....	57
5.4.2	Stopway Markings.....	58
5.4.3	Runway Holding Position Markings.....	58
5.5	Heliports	59
5.5.1	Heliport Touchdown and Lift-Off Area (TLOF) Marking.....	59
5.5.2	Safety Area Markers.....	59
5.5.3	Heliport Identification Markings.....	59
5.5.4	Final Approach and Take-Off Area (FATO) Markers.....	59
5.5.5	Helicopter Parking Position Markings.....	59
5.5.6	Approach and Take-Off Direction Indicator Markings.....	59
5.6	Closed Markings	59
5.7	Unserviceable Area Markers	60
5.8	Airside Signs	60
5.8.1	General.....	60
5.8.2	Information Signs.....	60
5.8.3	Mandatory Instruction Signs.....	61
5.8.4	Illumination of Airside Signs.....	62
5.9	Wind Direction Indicators	62
6.0	OBSTRUCTION MARKING AND LIGHTING	62
6.1	General	62
6.2	Regulations	62
6.3	Aeronautical Evaluation	63
6.4	Marking	63
6.5	Lighting	63
6.5.1	Rotating Obstruction Light.....	64
6.5.2	Tower Configurations.....	64
6.6	Appurtenances	65
6.7	Suspended Cable Span Markings	65
6.8	Aircraft Detection Systems	65
7.0	AERODROME LIGHTING	65
7.1	General	65
7.2	Aerodrome Beacon	66
7.3	Minimum Night Lighting Requirements at Aerodromes	66
7.4	Unserviceable Area Lighting	66
7.5	Approach Lighting	66
7.5.1	Non-Precision Approach Runways.....	66
7.5.2	Precision Approach Runways.....	67
7.6	Visual Approach Slope Indicator Systems (VASIS)	67
7.6.1	General.....	67
7.6.2	Visual Approach Slope Indicator (VASI) V1 and V2 and Abbreviated VASI (AVASI) AV.....	68
7.6.3	Precision Approach Path Indicator (PAPI) and Abbreviated PAPI (APAPI).....	68
7.6.4	Categories According to Eye-To-Wheel Height (EWH) in the Approach Configuration.....	68
7.6.4.1	General.....	68
7.6.4.2	Visual Approach Slope Indicator (VASI) Categories.....	69
7.6.4.3	Precision Approach Path Indicator (PAPI) Categories.....	69
7.6.5	Knowing the Eye-to-Wheel Height (EWH).....	69
7.6.6	Obstacle Protection Surface (OPS).....	69
7.7	Runway Identification Lighting	70

7.7.1	Runway Threshold Identification Lights (RTIL).....	70
7.7.2	Visual Alignment Guidance System (VAGS).....	70
7.8	Runway Lighting	70
7.8.1	Runway Edge Lights (REDL).....	70
7.8.2	Runway Threshold Lights and Runway End Lights (RENL).....	70
7.8.3	Displaced Threshold Lighting.....	71
7.8.4	Runway Centreline Lighting.....	71
7.8.5	Runway Touchdown Zone Lighting.....	71
7.9	Rapid-Exit Taxiway Indicator Lights (RETIL)	71
7.10	Taxiway Lighting.....	71
7.10.1	Taxiway Edge Lights	71
7.10.2	Taxiway Centreline Lights	72
7.10.3	Stop Bars	72
7.11	Runway Guard Lights.....	72
7.12	Heliport Lighting	73
7.12.1	Touchdown and Lift-Off Area (TLOF) Lighting	73
7.12.2	Final Approach and Take-Off (FATO) Lighting	73
7.12.3	Approach/Take-Off Direction Lights.....	73
7.13	Emergency Lighting	74
7.14	Aircraft Radio Control of Aerodrome Lighting (ARCAL)	74
7.15	Retroreflective Markers	74
8.0	AIRCRAFT RESCUE AND FIRE FIGHTING (ARFF).....	74
8.1	General.....	74
8.2	Aircraft Rescue and Fire Fighting (ARFF) Hours of Availability	74
8.3	Classification System	74
8.4	Aircraft Rescue and Fire Fighting (ARFF) Standby Request.....	75
8.5	Aircraft Rescue and Fire Fighting (ARFF) Discreet Communication	75
9.0	AIRCRAFT ARRESTING SYSTEMS	75
9.1	Engineered Material Arresting Systems (EMAS)	75
9.1.1	System Description	75
9.1.2	System Depiction.....	76
9.1.3	Pilot Considerations for Engagement	76
9.2	Military Aircraft Arresting Systems	76
9.2.1	Background	76
9.2.2	Markings.....	77
9.2.3	Operations	77
9.2.4	Damage Hazards	77
9.2.5	Information for Pilots.....	77
10.0	AIRPORT COLLABORATIVE DECISION MAKING (A-CDM)	77
10.1	Introduction	77
10.2	Operational Concept.....	77
10.3	Terms	78
10.4	Scope of Applicability	78
10.5	Airport Collaborative Decision Making (A-CDM) Procedures	79
10.5.1	Commercial Air Transport Operations — Procedures for Operators and Handling Agents.....	79
10.5.1.1	Requirement for All Flights to Have a Current Target Off-Block Time (TOBT)	79
10.5.1.2	Preferred Way of Providing the Target Off-Block Time (TOBT).....	79
10.5.1.3	Access to the Target Off-Block Time (TOBT)	79
10.5.1.4	Pre-Departure Sequencing — Target Start-Up Approval Time (TSAT) Generation	79
10.5.1.5	Access to the Target Start-Up Approval Time (TSAT)	79
10.5.1.6	Target Start-Up Approval Time (TSAT) Swapping	79
10.5.1.7	The Importance of Updating the Target Off-Block Time (TOBT)	79
10.5.1.8	Target Off-Block Time (TOBT) Update Limitations.....	79
10.5.1.9	Methods for Updating the Target Off-Block Time (TOBT).....	79
10.5.2	Commercial Air Transport Operations — Flight Crew Procedures	79
10.5.2.1	Target Off-Block Time (TOBT) and Target Start-Up Approval Time (TSAT) Delivery Channels.....	79
10.5.2.2	Access to the Target Off-Block Time (TOBT)	80

10.5.2.3	Access to the Target Start-Up Approval Time (TSAT)	80
10.5.2.4	Information Related to Airport Collaborative Decision Making (A-CDM) on the Advanced Visual Docking Guidance System (AVDGS).....	80
10.5.2.5	Call Ready Procedure	80
10.5.2.6	Procedures for Extended Times Between Target Off-Block Time (TOBT) and Target Start-Up Approval Time (TSAT).....	80
10.5.2.7	Airport Collaborative Decision Making (A-CDM)-Imposed Waiting Time and On-Time Performance.....	80
10.5.2.8	Pushback / Start-Up Approval	80
10.5.2.9	Flight Crew Concerns About Meeting Constraints.....	80
10.5.2.10	De-icing Operations.....	81
10.5.3	General and Business Aviation Operations — Air Operator Procedures.....	81
10.5.3.1	Prior Permission to Operate Required (Reservation)	81
10.5.3.2	Requirement to Provide the Target Off-Block Time (TOBT)	81
10.5.3.3	Pre-Departure Sequencing — Target Start-Up Approval Time (TSAT) Generation	81
10.5.3.4	Access to the Target Start-Up Approval Time (TSAT)	81
10.5.3.5	The Importance of Updating the Target Off-Block Time (TOBT)	81
10.5.3.6	Target Off-Block Time (TOBT) Update Limitations.....	81
10.5.3.7	Method for Updating the Target Off-Block Time (TOBT)	81
10.5.3.8	Target Off-Block Time (TOBT) and Target Start-Up Approval Time (TSAT) Delivery Channels.....	81
10.5.3.9	Access to the Target Off-Block Time (TOBT)	81
10.5.3.10	Access to the Target Start-Up Approval Time (TSAT)	82
10.5.3.11	Call Ready Procedure	82
10.5.3.12	Start-Up Procedures.....	82
10.5.3.13	Flight Crew Concerns About Meeting Constraints.....	82
10.5.3.14	De-icing Operations.....	82
10.6	Contingency Operations	82

AGA—AERODROMES

1.0 GENERAL INFORMATION

1.1 GENERAL

All flights into, from, or over the territory of Canada and all flights landing in such territory shall be carried out in accordance with Canada's civil aviation regulations. Aircraft arriving into or departing from the territory of Canada must first land at an aerodrome at which customs control facilities have been provided. For information about which aerodromes provide customs service, see the *Canada Flight Supplement* (CFS) or the *Canada Water Aerodrome Supplement* (CWAS), Section B, "Aerodrome/Facility Directory." If the heading CUST (customs) appears in the left-hand column of an aerodrome table, the aerodrome is an airport of entry (AOE) with customs service.

The privileges extended to aircraft are subject to proper authorization of each flight and to whatever restrictions the Government of Canada may, from time to time, or in specific cases, deem to be warranted.

1.1.1 Aerodrome Authority

Transport Canada is responsible for the surveillance of all certified civil aerodromes in Canada. Contact information for Transport Canada's offices can be found in GEN 1.1.1.

1.1.2 International Civil Aviation Organization (ICAO) Documents

See *ICAO Annex 14*, Volumes I and II.

1.1.3 Canadian Runway Friction Index (CRFI)

Many airports throughout Canada are equipped with mechanical and electronic decelerometers which are used to obtain an average of the runway friction measurement. The average decelerometer reading of each runway is reported as the CRFI. Experience has shown that results obtained from the various types of decelerometers on water, slush, wet snow, and dry snow exceeding a 1-inch depth are inaccurate, and the CRFI will not be available when these conditions are present.

Aerodromes equipped with runway friction decelerometer capability are listed in the CFS under RWY DATA.

Operational data relating to the reported average CRFI and the methods to be used when applying these factors to aircraft performance are presented in AIR 1.6.

1.1.4 Contaminated Runway Operations

1.1.4.1 Canadian Civil Aerodromes

At Canadian aerodromes where snow removal and ice control operations are conducted, assessment and mitigation procedures are carried out to the extent that is practicable in order to provide movement surfaces that will permit safe operational use.

Pilots who are confronted with conditions produced by the ever-changing Canadian climate must be familiar with and anticipate the overall effect of contaminated runways on aircraft handling characteristics in order to take any corrective actions considered necessary for flight safety.

In general terms, whenever a contaminant, such as water, snow, or ice, is present on the runway surface, the effective coefficient of friction between the aircraft tire and runway is reduced. However, the accelerate-stop distance, landing distance, and crosswind limitations contained in the AFM are demonstrated in accordance with specified performance criteria on dry runways during the aircraft certification flight test program and are thus valid only when the runway is dry.

As a result, the stop portion of the accelerate-stop distance will increase, the landing distance will increase, and a crosswind will present directional control difficulties.

It is therefore expected that pilots will take all necessary action, including the application of any appropriate adjustment factor to calculate stopping distances for their aircraft as may be required based on the RSC and CRFI information.

1.1.4.2 Department of National Defence Aerodromes

Snow removal and ice control policy and procedures at Canadian military aerodromes are similar to those of Canadian civil aerodromes; however, the military aerodrome operator might not use the same type of friction measuring equipment to obtain the average runway friction index.

1.1.5 Wildlife Hazard

Certified airports in Canada are required to have a plan to identify and control the hazards wildlife (birds and other animals) present to flight operations. The risk of wildlife strikes may increase during spring and autumn migrations; however, airports can be subject to hazardous wildlife year-round. Pilots should monitor ATIS for information concerning this hazard.

For more information on wildlife hazards, migratory birds, and wildlife-strike reporting, see *AIP Canada* ENR 5.6.

1.2 INTERNATIONAL AIRPORTS

Some airports are designated "international airport" by Transport Canada to support international commercial air transport. See *AIP Canada* GEN 1.2.2.1 for information on international commercial flights.

1.2.1 International Civil Aviation Organization (ICAO) Definitions

International Scheduled Air Transport, Regular Use (RS): An aerodrome which may be listed in the flight plan as an aerodrome of intended landing.

International Scheduled Air Transport, Alternate Use (AS): An aerodrome specified in the flight plan to which a flight may proceed when it becomes inadvisable to land at the aerodrome of intended landing.

International General Aviation, Regular Use (RG): All aircraft other than those operated on an international air service.

NOTE:

Any of the listed regular aerodromes may be used as a regular or alternate aerodrome.

1.3 AERODROME DIRECTORY

Complete general data on Canadian aerodromes is listed in the *Canada Flight Supplement* (CFS). ICAO Type A Charts are available from NAV CANADA's Aeronautical Information Management (AIM) (see MAP 4.2.1 and <https://www.navcanada.ca/en/aeronautical-information/instrument-flight-rules-ifr-publications-.aspx>).

1.4 AERONAUTICAL GROUND LIGHTS

Information on aeronautical ground lights can be found in the *Canada Flight Supplement* (CFS) under the LIGHTING entry in the table of the aerodrome they serve or on visual flight rules (VFR) navigational charts.

2.0 AERODROMES AND AIRPORTS

2.1 GENERAL

An aerodrome is defined by the *Aeronautics Act* as:

Any area of land, water (including the frozen surface thereof) or other supporting surface used, designed, prepared, equipped or set apart for use either in whole or in part for the arrival, departure, movement or servicing of aircraft and includes any buildings, installations and equipment situated thereon or associated therewith.

This has a very broad application for Canada where there are no general restrictions preventing landings or takeoffs. There are defined exceptions, but, for the most part, all of Canada can be an aerodrome.

Rules for operating an aerodrome are provided in Part III of the Canadian Aviation Regulations (CARs) under Subpart 301. The objective is to define the minimum safety standards that must be offered as well as to make provision for inspection by the Minister. Aerodrome operators are encouraged, in the interest of aviation safety, efficiency, and convenience, to improve their aerodromes beyond the basic regulatory requirements using, as guidelines, the standards and recommended practices applicable for the certification of aerodromes as airports, heliports, or water

airports. Aerodrome users are, however, reminded that the improvement of aerodrome physical characteristics, visual aids, lighting, and markings beyond the basic regulatory requirements for aerodromes stated in CAR 301 is a matter of individual aerodrome operators' initiative. Such improvements do not require regulatory compliance, nor are those improvements inspected or certified in accordance with the standards and recommended practices applicable for the certification of aerodromes as airports, heliports, or water airports.

2.1.1 Registration

Subsection 301 also regulates the "Registration" process, which is used to publish and maintain information on an aerodrome in the CFS or the CWAS. The regulation specifies that an aerodrome operator can expect:

- to have their aerodrome registered in the appropriate publication when they provide the necessary information with respect to location, markings, lighting, use, and operation of the aerodrome;
- to have their aerodrome denied registration in the appropriate publication if they do not meet the aerodrome regulatory requirements for markers and markings, warning notices, wind direction indicator, and lighting;
- to assume responsibility of immediately notifying the Minister of any changes in the aerodrome's published information regarding its location, markings, lighting, use, or operation; and
- to have their aerodrome classed as a registered aerodrome when it is published in the CFS or CWAS.

NOTE:

No aerodrome operator is obliged by these regulations to have information published in the CFS or CWAS. The Minister may choose not to publish information for a site that is considered to be hazardous to aviation safety.

In addition to the initial inspection during the application for registration, other inspections are done on an as-required basis, once the aerodromes are registered, to verify their compliance with CARs and the accuracy of their information as it is published in the CFS or the CWAS. Such information, however, is only published for the convenience of the pilot and should be confirmed through contact with the aerodrome operator before the pilot uses a site.

2.1.2 Certification

Besides "aerodrome" and "registered aerodrome," other terms include "airport," "heliport," and "water airport." These are aerodromes for which a certificate has been issued under Subpart 302 of the CARs or Subpart 305 for heliports. The objective is to protect those, such as the fare-paying public and residents in the vicinity of an airport, who do not have the knowledge or ability to protect themselves and who could thus be affected by unsafe operations. This is achieved by ensuring sites are inspected periodically for compliance with Transport Canada standards for obstacle limitation surfaces,

physical characteristics, marking, lighting, maintenance procedures, emergency response services, etc., which have been recorded in the Airport/Heliport Operations Manual. The current information is to be communicated to all interested aircraft operators through the CFS, the CAP, NOTAMs, and voice advisories, as applicable. See AGA 2.3 for more information about aerodrome certification.

2.2 USE OF AERODROMES, AIRPORTS, AND HELIPORTS

An aerodrome, airport, or heliport listed in the *Canada Flight Supplement* (CFS) or the *Canada Water Aerodrome Supplement* (CWAS) that does not require prior permission of the aerodrome or airport operator for aircraft operations is called a public-use aerodrome, airport, or heliport.

An aerodrome, airport, or heliport that can be listed in the CFS or CWAS but whose use can be limited is called a private-use aerodrome. This can include:

- (a) **Prior Permission Required (PPR):** The aerodrome operator's permission is required prior to use. All military aerodromes require PPR for Civilian aircraft.
- (b) **Prior Notice Required (PN):** The aerodrome operator owner or operator is to be notified prior to use so that current information on the aerodrome may be provided.

NOTES:

1. Pilots and aerodrome operators are reminded that trespass restrictions are not applicable to aircraft in distress.
2. Pilots intending to use a non-certified aerodrome are advised to obtain current information from the aerodrome operator concerning operating conditions prior to using that aerodrome for aircraft operations.

2.3 AIRPORT/HELIPORT/WATER AIRPORT CERTIFICATION

2.3.1 General

Transport Canada is responsible for the regulatory development and compliance oversight in support of a safe national air transportation system. Therefore, airports supporting commercial operations involving the carrying of passengers must meet accepted safety standards. The airport operator that holds an airport certificate testifies that the aerodrome meets such safety standards. Where variances from airport certification safety standards are required, studies will be undertaken to devise offsetting procedures, which will provide equivalent levels of safety.

2.3.2 Applicability of Airport Certification

The requirement for aerodrome certification applies to:

- (a) any aerodrome that is located within the built-up area of a city or town;
- (b) any land aerodrome that is used by an air operator for the purpose of a scheduled service for the transport of passengers; and
- (c) any other aerodrome, where the Minister is of the opinion that it is in the public interest for that aerodrome to meet the requirements necessary for the issuance of an airport certificate because it would further the safe operation of the aerodrome.

Exemptions include:

- (a) military aerodromes; and
- (b) aerodromes for which the Minister has written an exemption and an equivalent level of safety is defined.

2.3.3 Transport Canada's Responsibilities

The responsibilities of Transport Canada include:

- (a) developing safety standards, policies, and criteria for elements such as, but not limited to:
 - (i) physical characteristics of the manoeuvring area, including separations,
 - (ii) marking and lighting, and
 - (iii) obstacle limitation surfaces in the vicinity of airports, heliports and water airports;
- (b) reviewing aeronautical studies where variances from airport certification safety standards are required;
- (c) certifying and inspecting against the requirements and conditions of the respective operations manuals (for airports, heliports, or water airports); and
- (d) verifying, amending, and relaying, as appropriate, pertinent airport/heliport/water airport information to be identified in the appropriate AIS publications.

2.3.4 Operator's Responsibilities

The responsibilities of the operator of an airport/heliport/water airport include, but are not limited to:

- (a) complying with the applicable regulations and standards in Part III of CARs;
- (b) completing and distributing an approved operations manual;
- (c) maintaining the facility in accordance with the requirements specified in the airport/heliport/water airport operations manual; and
- (d) advising Transport Canada and aircraft operators whenever services or facilities fall below requirements prescribed in the operations manual or differ from the information published in the aeronautical publications for their aerodrome.

2.3.5 Airport Certification Process

Airport certification is a process whereby Transport Canada certifies that an aerodrome meets airport certification safety standards and that aerodrome data, as provided by the owner or operator and as confirmed by Transport Canada inspectors at the time of certification, is correct and published in the appropriate aeronautical information publications. When these requirements are met, an airport certificate is issued. The airport certificate documentation includes:

- (a) the airport certificate, which certifies that the airport meets required standards at the time of issuance; and
- (b) the operations manual, which details the airport specifications, facilities, and services, and specifies the responsibilities of the operator for the maintenance of airport certification standards. The operations manual is a reference for airport operations and inspections, which ensures that variances from airport certification safety standards and the resulting conditions of airport certification are approved.

2.3.6 Regulatory References for Aerodrome Certification (Airport/Heliport/Water Airport)

The regulatory authority for airport, heliport, and water airport certification is Subpart 302 of the CARs. The regulatory authority for heliport certification can be found under Part III of the CARs, which includes reference to the respective compliance standards for aerodrome certification. Depending on the date on which the certificate was initially issued, some aerodrome operators may be complying with previous versions of the certification standards.

2.4 AIRPORT/HELIPORT/WATER AIRPORT CERTIFICATE

2.4.1 Issue

A certificate will be issued when an inspection confirms that all requirements for airport certification have been met, including the following:

- (a) where variance from the certification standards exists, measures have been implemented to provide for an equivalent level of safety; and
- (b) the operations manual has been approved by the Regional Director, Civil Aviation.

2.4.2 Airport Certificate Validity and Amendments

The airport certificate is a legal aviation document that remains valid as long as the airport is operated and maintained in accordance with the operations manual. Periodic inspections are conducted to verify continued conformity to the certification standards and conditions specified in the operations manual.

Transport Canada may make amendments to the conditions applicable to the issuing of an airport certificate when:

- (a) an approved variance from certification standards and a change in the conditions of certification are required;
- (b) there is a change in the use or operations of the airport; and
- (c) it is requested by the holder of the airport certificate.

3.0 RUNWAY CHARACTERISTICS

3.1 RUNWAY LENGTH AND WIDTH

Runways are generally dimensioned to accommodate an aircraft considered to be the critical aircraft. Critical aircraft is defined in the fifth edition of the Transport Canada publication titled *Aerodrome Standards and Recommended Practices* (TP 312) as “the aircraft identified as having the most demanding operational requirements with respect to the determination of movement area dimensions, and other aerodrome physical characteristics at the aerodrome or part thereof”. To identify the critical aircraft, flight manual performance data of a variety of aircraft is examined. Once the critical aircraft has been determined, the longest distance determined after analyzing both take-off and landing performance is used as the basis for runway dimensions. Generally, the runway width can be increased by a maximum of 60 m as a function of length.

3.2 RUNWAY STRIP

Each runway is bounded by a runway strip on its sides and ends to protect aircraft that overfly the runway at very low altitudes during a balked approach for landing. This is achieved by restricting the presence of objects to only those that must be in proximity of the runway as part of normal operations and by prescribing frangibility requirements.

3.3 RUNWAY SAFETY AREA

Each runway is bounded by a prepared area on its sides and ends, within the dimensions of the runway strip. It is graded to prevent catastrophic damage to aircraft leaving the runway sides.

3.4 RUNWAY END SAFETY AREA (RESA)

On some runways there may be an area, at the end and beyond the runway strip, prepared to reduce the severity of damage to an aircraft overrunning or undershooting the runway.

3.5 RUNWAY THRESHOLD DISPLACEMENT

Occasionally, natural and human-made obstacles penetrate the obstacle limitation surfaces of the approach paths to runways.

To ensure that a safe clearance from these obstacles is maintained, it is necessary to displace the threshold upwind from the adjacent runway end where the approach slope cannot be raised. In the case of runways for which instrument approach procedures (IAP) are published in the *Canada Air Pilot* (CAP), the usable runway distances for landings and takeoffs are specified as declared distances. The displacements are also depicted on the aerodrome or airport diagram in both the CAP and the *Canada Flight Supplement* (CFS). For other runways that do not have approaches published in the CAP, the requisite data is given in the CFS. Where a threshold is displaced, it is marked as shown in AGA 5.4.1, Figure 5.5.

When the portion of the runway preceding the threshold is marked with arrows (see AGA 5.4.1), it is permissible to use that portion of the runway for taxiing, takeoff, and landing roll-out from the opposite direction. When taking off from the end opposite the threshold, pilots should be aware of the fact that there are obstacles present that have penetrated above the approach slope leading to the physical end of the runway and have resulted in the threshold being displaced. In some cases, this may result in the publication of a specified climb and/or visibility.

3.6 RUNWAY TURN PAD

Some runways have thresholds that are not served directly by taxiways. In such cases, there may be a runway turn pad, a widened area that can be used to facilitate turnaround. Pilots are cautioned that these pads do not give sufficient clearance from the runway edge and thus cannot be used for holding while other aircraft are using the runway.

3.7 BLAST PAD

A blast pad is defined in the *Aerodrome Standards and Recommended Practices* (TP 312) as “an area before the threshold that is prepared to resist erosion arising from jet exhaust or propeller wash.” When over 60 m in length, this entire paved, non-load-bearing surface is marked with yellow chevrons, as shown in AGA 5.4.2, Figure 5.6.

3.8 STOPWAY

A stopway is defined in the *Aerodrome Standards and Recommended Practices* (TP 312) as “a rectangular area on the ground at the end of take-off run available prepared as a suitable area in which an aeroplane can be stopped in the case of a rejected takeoff”. Where paved, it is marked over its entire length with yellow chevrons (when its length exceeds 60 m) as shown in AGA 5.4.2, Figure 5.6, and is lit with red edge and end lights in the take-off direction. Its length is included in the accelerate-stop distance available (ASDA) declared for the runway.

3.9 CLEARWAY

A clearway is defined in the *Aerodrome Standards and Recommended Practices* (TP 312) as “a defined rectangular area over land or water under the control of the aerodrome operator, selected as a suitable area over which an aircraft may make a portion of its initial climb to a specified height”.

3.10 DECLARED DISTANCES

The *Canada Air Pilot* (CAP) provides information on declared distances, which are defined in the fifth edition of the *Aerodrome Standards and Recommended Practices* (TP 312) as follows:

“The distances that the aerodrome operator declares available for aircraft take-off run, take-off distance, accelerate stop distance, and landing distance requirements. The distances are categorized as follows:

- Take-off run available (TORA): The length of runway declared available and suitable for the ground run of an aircraft taking off.
- Take-off distance available (TODA): The length of the takeoff run available plus the length of the clearway, if provided.
- Accelerate-stop distance available (ASDA): The length of the takeoff run available plus the length of the stopway, if provided.
- Landing distance available (LDA): The length of the runway available and suitable for the ground run of an aircraft landing.”

3.11 RAPID-EXIT TAXIWAYS

To reduce the aircraft runway occupancy time, some aerodromes or airports provide rapid-exit taxiways, which are connected to the runway at an angle of approximately 30 degrees.

3.12 RUNWAY AND TAXIWAY BEARING STRENGTH

The bearing strength of some aerodrome or airport pavement surfaces (runways, taxiways, and aprons) that is required to withstand continuous use by aircraft of specific weights and tire pressures has been assessed at specific locations. The Transport Canada (TC) pavement load rating (PLR) and International Civil Aviation Organization (ICAO) pavement classification number (PCN) define the weight limits at or below which the aircraft may operate on pavements without prior approval of the aerodrome or airport authority. The tire pressure and aircraft load rating (ALR)/aircraft classification number (ACN) must be equal to or less than the PLR/PCN figures published for each aerodrome or airport. Aircraft exceeding the published load restrictions may be permitted for limited operations following an engineering evaluation by the airport operator. Requests to permit such operations should be forwarded to the airport operator and should include the aircraft type, operating weight, and tire pressure, as well as the frequency of the proposed operation and the pavement areas required at the aerodrome or airport.

3.12.1 Pavement Load Rating Charts

Operators who require information about the aircraft weight limitations in effect at an aerodrome or airport can contact the aerodrome or airport operator.

3.13 HELIPORTS

Because of the unique operational characteristics of helicopters, a heliport's physical characteristics differ significantly from the physical characteristics of other aerodromes. For instance, a heliport does not require a runway, but instead requires a final approach and take-off area (FATO). The FATO is 1.5 times larger than the longest helicopter for which the heliport is certified and is surrounded by a safety area, which is to be kept free of obstacles, other than visual aids.

Figure 3.1—FATO/Safety Area

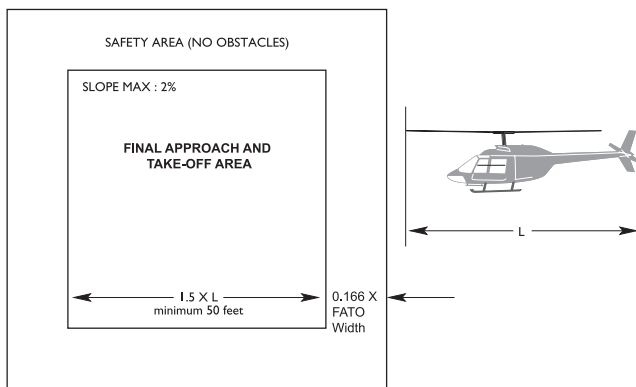

3.13.1 Final Approach and Take-Off Area (FATO)

Obstacle-free arrival and departure paths to and from a FATO are always required. In some cases, a FATO can be offset from the intended landing area. In this case, helicopter parking positions are established on an apron area and pilots will hover taxi to transition between the FATO and the parking position.

Figure 3.2—Heliport General Layout

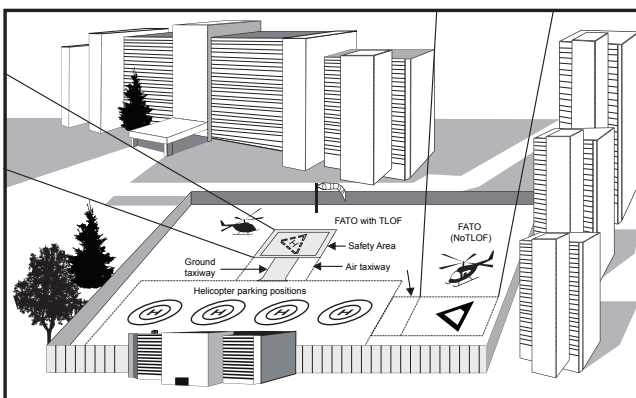

3.13.2 Heliport Classification

Non-instrument heliports have three classifications: H1, H2, and H3.

H1 heliports have no suitable or available emergency landing areas within 625 m of the FATO. Their use is restricted to multi-engine helicopters capable of remaining 4.5 m above all obstacles within the defined approach/departure pathways when operating in accordance with their AFM with one engine inoperative.

H2 heliports do have suitable and available emergency landing areas within 625 m of the FATO; however, they may only be used by multi-engine helicopters because the associated approach slopes are higher due to high obstacles within the approach/departure pathways.

H3 heliports have suitable and available emergency landing areas within 625 m of the FATO and no obstacles that penetrate the OLSs; they may therefore be used by single- or multi-engine helicopters. Heliport classifications are specified in the CFS.

3.13.3 Heliport Operational Limitations

All heliports have three operational limitations. The limitations for each specific heliport are listed in the CFS.

The load-bearing strength shall be identified for each elevated or rooftop FATO or floating supporting structure. Surface-level heliports do not need to list a load-bearing strength.

The maximum helicopter overall length shall be identified for each FATO. This is calculated as the width or diameter of each FATO, divided by 1.5. This number represents the largest size of helicopter for which the FATO is certified.

The heliport category (instrument or non-instrument) and classification, as detailed in AGA 3.13.2, above, shall also be listed.

4.0 OBSTACLE RESTRICTIONS

4.1 GENERAL

The safe and efficient use of an aerodrome, airport, or heliport can be seriously compromised by the presence of obstacles within or close to the take-off or approach areas. The airspace in the vicinity of take-off or approach areas, which is to be maintained free from obstacles so as to facilitate the safe operation of aircraft, is defined for the purpose of:

- (a) regulating aircraft operations where obstacles exist;
- (b) removing obstacles; or
- (c) preventing the creation of obstacles.

4.2 OBSTACLE LIMITATION SURFACES (OLS)

4.2.1 General

An OLS establishes the limit to which objects may project into the airspace associated with an airport so that aircraft operations at the airport may be conducted safely. It includes an approach surface, a take-off surface, and a transitional surface.

Figure 4.1—Example of OLSs

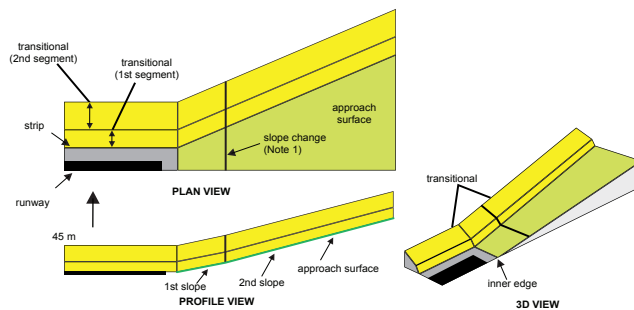

4.2.2 Heliports

Heliports are normally served by two approach and departure paths. In some instances, they only have one approach and departure path and will then require a transitional surface.

Figure 4.2—Heliport Take-off/ Approach Areas and Surfaces

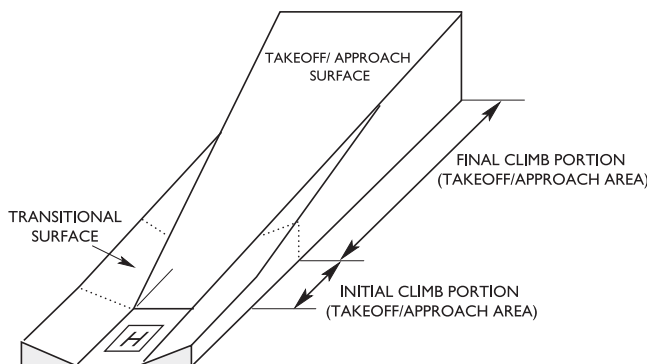

4.3 AIRPORT ZONING REGULATIONS

4.3.1 General

An airport zoning regulation is a regulation applicable to a given airport pursuant to section 5.4(2) of the Aeronautics Act that imposes restrictions on land use, including vertical development, with the objective of protecting an airport’s current and future accessibility, usability, and viability by:

- (a) preventing lands adjacent to or in the vicinity of a federal airport or an airport site from being used or developed in a manner that is, in the opinion of the Minister, incompatible with the operation of an airport;
- (b) preventing lands adjacent to or in the vicinity of an airport or airport site from being used or developed in a manner that is, in the opinion of the Minister, incompatible with the safe operation of an airport or aircraft; and
- (c) preventing lands adjacent to or in the vicinity of facilities used to provide services relating to aeronautics from being used or developed in a manner that would, in the opinion of the Minister, cause interference with signals or communications to and from aircraft or to and from those facilities.

NOTE:

An airport zoning regulation applies only to land outside the boundary of the airport it protects. Obstacles within an airport boundary must not penetrate an OLS for the runway(s) involved unless the obstacle is exempted as a result of an aeronautical study.

4.3.2 Airports Where Zoning Regulations Are in Effect

A list of airports where airport zoning regulations are in effect is maintained in the Regional Aerodrome Safety office and online on the Aeronautics Act page of the Department of Justice Web site, under the heading “Regulations made under this Act”.

5.0 MARKERS, MARKINGS, SIGNS, AND INDICATORS

5.1 AIRCRAFT TAKE-OFF OR LANDING AREA BOUNDARY MARKERS

The take-off or landing area boundaries of aerodromes without prepared runways are indicated by conical- or gable-type markers (highway-type cone markers are acceptable) or by evergreen trees in winter. No boundary markers are required if the entire movement area is clearly delineated from that of the surrounding ground. The markers are typically coloured international orange and white or solid international orange.

AGGA

Figure 5.1—Examples of Conical and Gable Markers

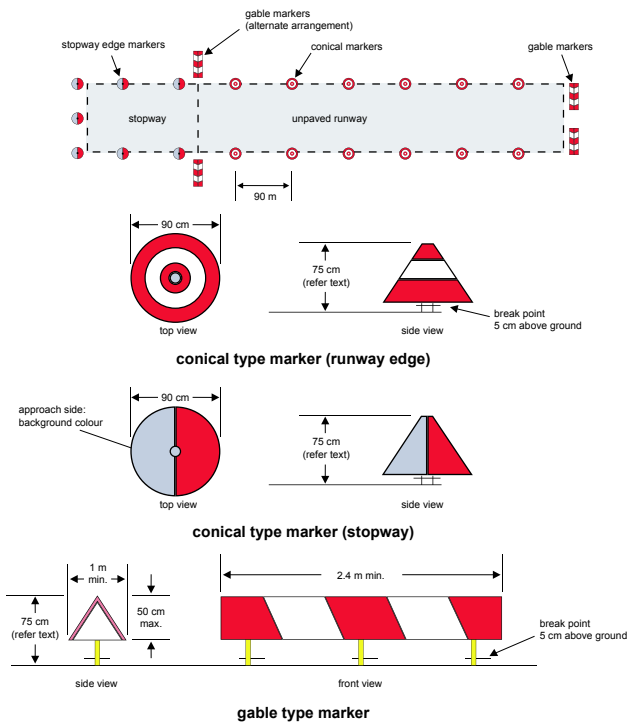

5.3 SEAPLANE DOCK MARKERS

Seaplane docks are marked to facilitate their identification. The dock is marked with an equilateral triangle measuring 2.4 m on each side. The dock to which this marker is affixed also has red and white side markings.

Figure 5.3—Seaplane Dock Markers

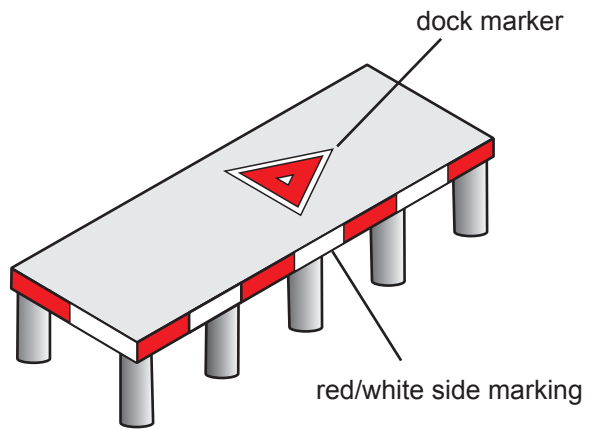
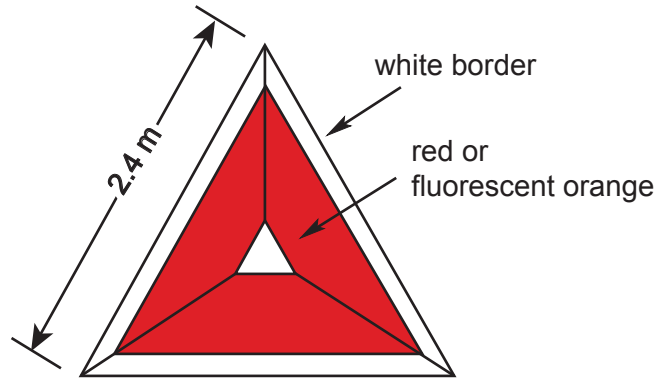

5.2 AIR TAXIWAY EDGE MARKERS

The edges of the air taxiway route are indicated by markers 35 cm in height that consist of three horizontal bands of equal size arranged vertically. The top and bottom bands are yellow and the middle one is green.

Figure 5.2—Air Taxiway Edge Marker



5.4 RUNWAY MARKINGS

Runway markings vary depending on the runway’s length, width, surface type, and, if available, aircraft group number (AGN). They are described in detail in Transport Canada’s *Aerodrome Standards and Recommended Practices* (TP 312).

Where an aiming point marking is provided, it is white and located at a specific distance from the threshold per Table 5.1 below.

Table 5.1—Location of Aiming Point Marking

Declared landing distance available (LDA)	Location of aiming point marking distance from threshold (m)
less than 800 m	150
800 m up to but not including 1 200 m	250
1 200 m up to but not including 2 400 m	300
2 400 m or more	400

Where touchdown zone (TDZ) markings are provided, they are white and found in pairs in accordance with Table 5.2 and Figure 5.4 below. The location of pairs of TDZ markings is based on a horizontal spacing of 150 m. However, aiming point markings take precedence over TDZ markings; therefore, a pair of TDZ markings is omitted if it would otherwise fall within 50 m of the aiming point marking.

Figure 5.4—Aiming Point and TDZ Markings

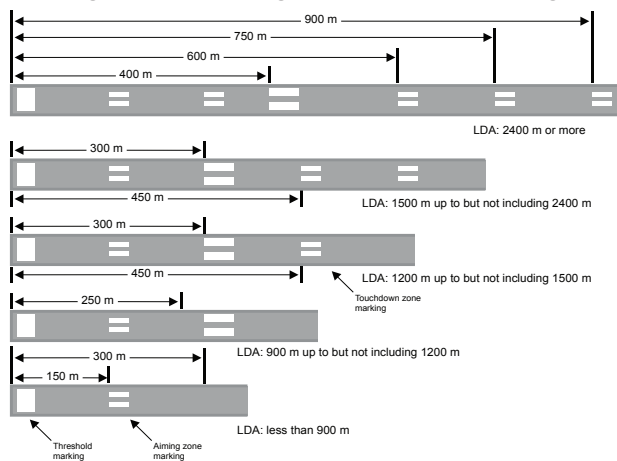

5.4.1 Displaced Threshold Markings

Figure 5.5—Displaced Threshold Markings

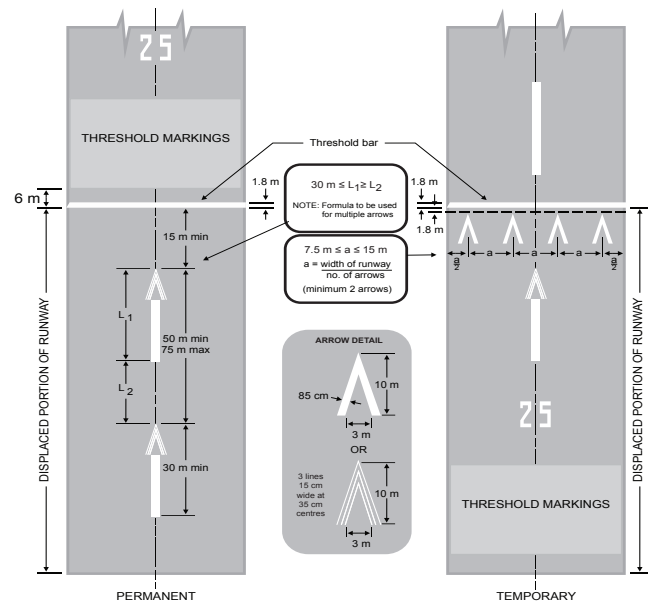

NOTE:

When the threshold must be displaced for a relatively short period of time, painting a temporary threshold bar is impractical. Instead, flags, cones, or wing bar lights are installed to indicate the position of the displaced threshold. A NOTAM or voice advisory warning of the temporary displacement will contain a description of the markers and the expected duration of the displacement in addition to the length of the closed portion and the remaining usable runway.



5.4.2 Stopway Markings

The paved area preceding a runway threshold prepared, maintained, and declared as a stopway is marked with yellow chevrons when its length exceeds 60 m. This area is not available for taxiing, the initial take-off roll, or the landing rollout. The chevron markings may also be used on blast pads.

Table 5.2—TDZ Marking Pairs

Distance between thresholds/declared LDA	Location of TDZ markings distance from threshold (m)	Location of aiming point marking distance from threshold (m)	Pairs of TDZ markings
less than 900 m	0	150	0
900 m up to but not including 1 200 m	150	250	1
1 200 m up to but not including 1 500 m	150 and 450	300	2
1 500 m up to but not including 2 400 m	150, 450 and 600	300	3
2 400 m or more	150, 300, 600, 750 and 900	400	5

Figure 5.6—Stopway Markings

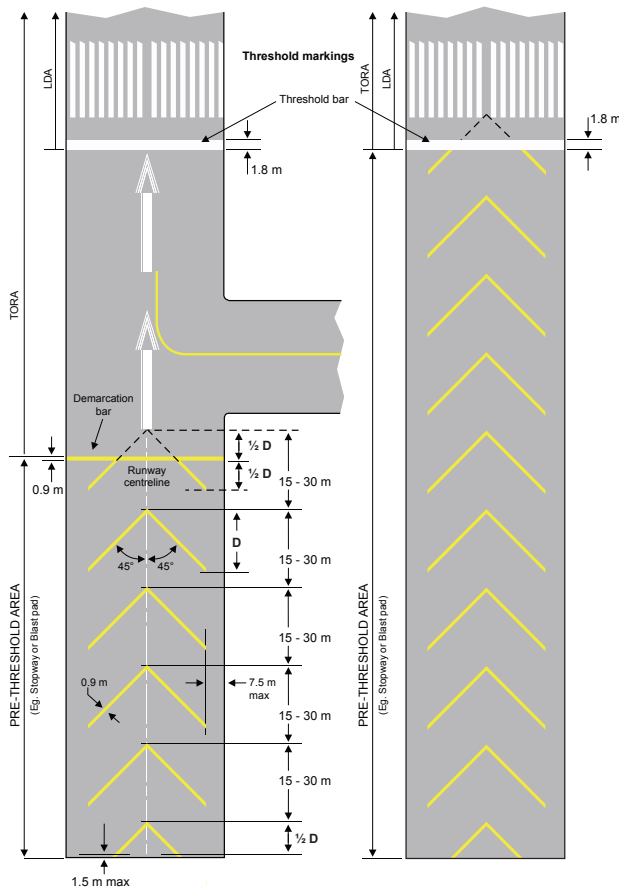

5.4.3 Runway Holding Position Markings

Runway holding position markings are provided near all runway/taxiway intersections and runway/runway intersections to protect the operational environment of the runway in use. They may also be established at other locations to protect the arrival and departure flight paths to a runway.

The standard runway holding position marking consists of two solid and two dashed lines as depicted in Figure 5.7.

Some airports may have multiple runway holding position markings on a given taxiway. These additional markings are commonly referred to as having a ladder-type pattern as depicted in Figure 5.7. It is important to note that in all cases, the runway holding position marking nearest to the runway will be the standard presentation.

Figure 5.7—Runway Holding Position Markings

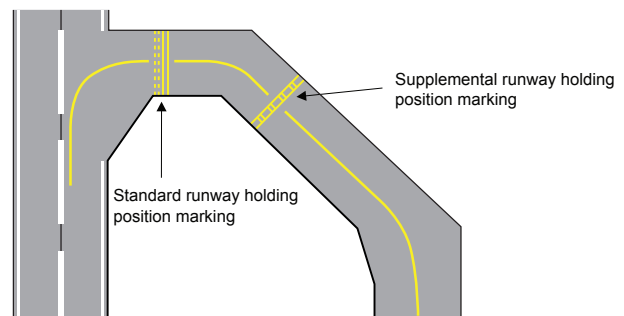

5.5 HELIPORTS

5.5.1 Heliport Touchdown and Lift-Off Area (TLOF) Marking

When the perimeter of the TLOF is not otherwise obvious, it will be marked by a solid white line.

5.5.2 Safety Area Markers

The safety area that surrounds the FATO may be indicated by gable, conical, or other types of suitable markers or markings.

5.5.3 Heliport Identification Markings

Heliports are identified by a white capital letter “H” centred within the TLOF. Where it is necessary to enhance the visibility of the letter “H”, it may be centred within a dashed triangle. Hospital heliports are identified by a red capital letter “H” centred within a white cross.

The letter “H” will be oriented with magnetic north, except in the area of compass unreliability, where it will be oriented with true north.

Figure 5.8—Heliport Identification Markings

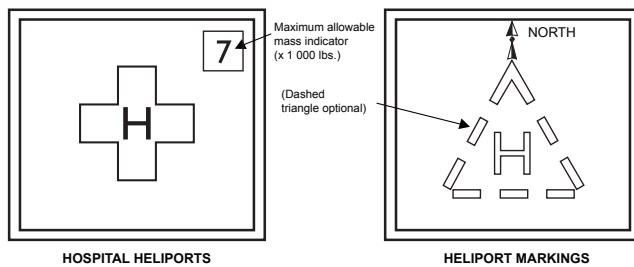

5.5.4 Final Approach and Take-Off Area (FATO) Markers

Where practicable, the boundary of the FATO will be indicated by gable, conical, or other types of suitable markers. The markers shall be frangible and shall not exceed a height of 25 cm. An aiming point marking will be provided and located in the centre of the FATO, where practicable. Where the direction of the helicopter parking position is not obvious, an indicator will show its direction.

5.5.5 Helicopter Parking Position Markings

Helicopter parking position markings consist of two concentric yellow circles. The diameter of the outer circle shall not be less than 1.2 times the overall length of the longest helicopter for which the helicopter parking position is certified. The diameter of the inner circle is one-third of the size of the outer circle. An “H” marking will be centred within the inner circle.

Figure 5.9—Helicopter Parking Position Markings

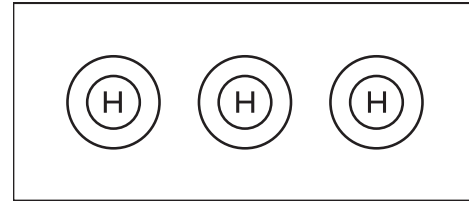

5.5.6 Approach and Take-Off Direction Indicator Markings

There may be heliports where, due to nearby obstacles or noise-sensitive areas, approach and take-off directions are designated. The direction of the approach and take-off paths is indicated by a double-headed arrow, showing their inbound and outbound directions. The arrows are located beyond the edge of the safety area or on the aiming point marking.

Figure 5.10—Approach and Take-Off Direction Marking

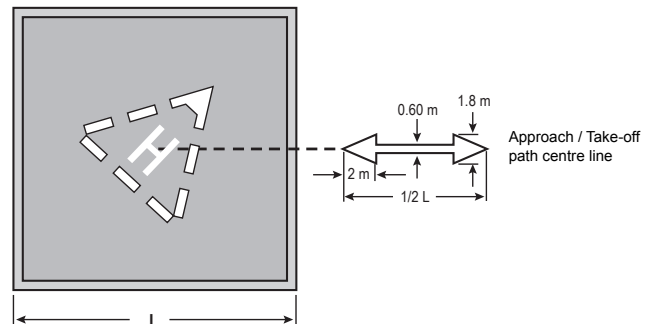

5.6 CLOSED MARKINGS

The closed portion of the runway may be shown on the aerodrome or airport diagram in the *Canada Flight Supplement* (CFS) and the *Canada Air Pilot* (CAP) for identification purposes; however, declared distances will only include runway length starting at the new threshold position.

Runways, taxiways, helicopter final approach and take-off areas (FATO), and other helicopter areas that are closed to operations are marked by “Xs”, as shown in Figure 5.11. Snow-covered areas may be marked by “Xs” using conspicuously coloured dye.

“Xs” applied to runways are white in colour and placed within a maximum spacing of 300 m of each other. For taxiways, the “Xs” are yellow in colour and placed at each end of the closed portion.

For helicopter FATOs, the “X” is white in colour. For other helicopter areas such as helicopter parking positions, the “X” is yellow in colour.

Figure 5.11—Closed Markings

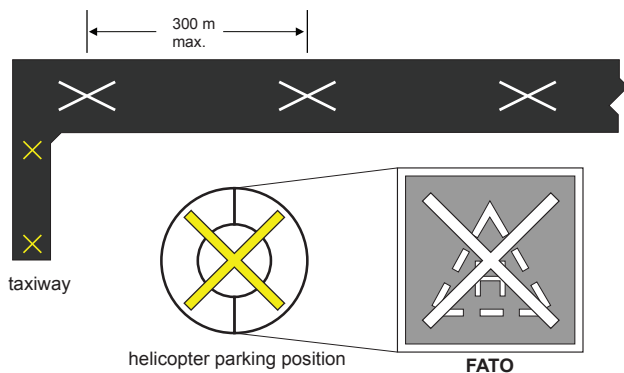

A lighted “X” may also be used within 75 m of the threshold to mark a temporary full-length closure of a runway.

Figure 5.12—Lighted “X” Marking a Temporary Full-Length Runway Closure



5.7 UNSERVICEABLE AREA MARKERS

Unserviceable portions of the movement area other than runways and taxiways are delineated by markers such as marker boards, cones, or red flags and, where appropriate, a flag or suitable marker is placed near the centre of the unserviceable area. Red flags are used when the unserviceable portion of the movement area is sufficiently small for it to be by-passed by aircraft without affecting the safety of their operations.

5.8 AIRSIDE SIGNS

5.8.1 General

The primary purpose of airside signs is to ensure the safe and expeditious movement of aircraft on the aprons, taxiways, and runways by providing direction and information to pilots.

The two main categories of airside signs are information signs and mandatory instruction signs, differentiated by using black/yellow and red/white colour combinations, respectively.

5.8.2 Information Signs

Information signs identify a specific destination, location, frequency, or routing information to pilots. The inscriptions incorporate arrows, numbers, letters, or pictographs to convey instructions or to identify specific areas.

- (a) **Location Sign:** A location sign has a yellow inscription on a black background and is used to identify the taxiway that the aircraft is on or entering. A location sign never contains arrows.
- (b) **Direction Sign:** A direction sign has a black inscription on a yellow background and is used to identify the intersecting taxiways toward which an aircraft is approaching. The sign is, whenever practicable, positioned on the left-hand side of the taxiway and prior to the intersection. A direction sign will always contain arrows to indicate the approximate angle of intercept. Direction signs are normally used in combination with location signs to provide the pilot with position information. The location sign will be in the centre or datum position. In this configuration, all left turn direction signs are located to the left of the location sign and all right turn direction signs are located to the right of the location sign.

The only exception to this rule is for a simple “T” intersection, where the information sign is located on the opposite side (the top of the “T”) of the intersection, facing the taxiway.

When a taxiway continues through the intersection and changes heading by more than 25° or changes its designation, a direction sign will indicate this fact.

- (c) **Runway Exit Signs:** A runway exit sign has a black inscription on a yellow background and is used to identify a taxiway that exits a runway. The sign is positioned prior to the intersection on the same side of the runway as the exit. The sign will always contain an arrow and will indicate the approximate angle at which the taxiway intersects the runway. When a taxiway crosses a runway, a sign will be positioned on both sides of the runway. Runway exit signs may be omitted in cases where aircraft do not normally use the taxiway to exit or in cases of one-way taxiways.

Figure 5.16—Mandatory Instruction Signs

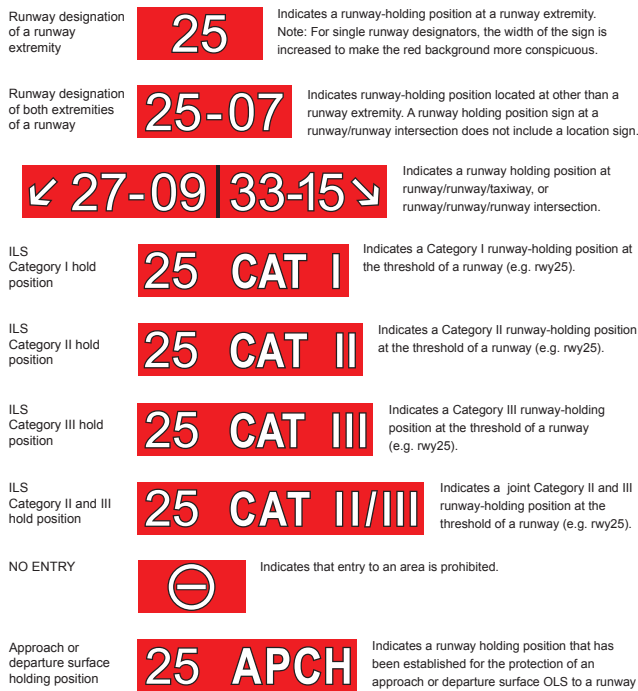

5.8.4 Illumination of Airside Signs

Airside signs are illuminated at airports that are used at night or in low visibility. Signs, which are illuminated internally, may be of two types. One type has a sign face constructed from material, such as plexiglass, which permits the entire sign face to be illuminated. The other type has a sign face that incorporates imbedded fibre optic bundles that illuminate the individual letters, numbers, and arrows, not the face of the sign. At night or in low visibility, pilots approaching a fibre optic sign will see RED illuminated characters on mandatory instruction signs, YELLOW characters on a location sign, and WHITE characters on all other information signs.

5.9 WIND DIRECTION INDICATORS

At aerodromes that do not have prepared runways, the wind direction indicator is usually mounted on or near some conspicuous building or in the vicinity of the general aircraft parking area.

Runways greater than 1 200 m in length will have a wind direction indicator for each end of the runway. It will be typically located adjacent to the touchdown zone, 60 m outward from the edge of the runway, and clear of the obstacle-free zone.

Runways 1 200 m in length and shorter will have a wind direction indicator located centrally on the aerodrome or near each end of the runway, typically positioned in proximity to the aiming point markings.

For night operations the wind direction indicator will be illuminated.

NOTE:

At aerodromes certified as airports, a dry standard wind direction indicator will react to wind speed as follows:

Table 5.3—Wind Indicator Angle Based on Wind Speed

Wind Speed	Wind Indicator Angle
15 kt or above	Horizontal
10 kt	5° below horizontal
6 kt	30° below horizontal

At aerodromes not certified as airports, non-standard wind indicator systems, which could react differently to wind speed, may be in use.

6.0 OBSTRUCTION MARKING AND LIGHTING

6.1 GENERAL

Where an object, regardless of its height, has been assessed as constituting an obstacle to air navigation as per subsection 601.23(1) of the *Canadian Aviation Regulation (CARs)*, it requires marking and/or lighting in accordance with the standards specified in CAR Standard 621.

6.2 REGULATIONS

Sections 601.23–601.27 of the *Canadian Aviation Regulations (CARs)* provide regulations regarding marking and lighting of obstacles to air navigation. The following objects are marked and/or lighted in accordance with the standards specified in CAR Standard 621:

- (a) any object penetrating an airport obstacle limitation surface (OLS) as specified in Chapter 4 of *Aerodrome Standards and Recommended Practices (TP 312)*;
- (b) any object greater than 90 m above ground level (AGL) within 6 km of the geographical centre of an aerodrome;
- (c) any object greater than 90 m AGL within 3.7 km of the imaginary centreline of a recognized visual flight rules (VFR) route, including but not limited to a valley, a railroad, a transmission line, a pipeline, a river, or a highway;
- (d) any permanent catenary wire crossing where any portion of the wires or supporting structures exceeds 90 m AGL;
- (e) any object greater than 150 m AGL; and
- (f) any other object, other than the above, deemed by the Minister to represent a likely hazard to aviation safety, in accordance with section 601.25 of the CARs.

6.3 AERONAUTICAL EVALUATION

A person planning to erect or modify an obstacle, namely a building, structure, or object, including a moored balloon or kite, either permanently or temporarily, is required to contact the appropriate regional Transport Canada Civil Aviation office at least 90 days prior to erection and provide the information on the planned obstruction, using Form 26-0427E, *Aeronautical assessment form for obstacle notice and assessment*, available in Transport Canada's forms catalogue at <https://wwwapps.tc.gc.ca/Corp-Serv-Gen/5/forms-formulaires/search/results?Keywords=&FormNumber=26-0427&TransportationMode=&Format=&ResultView=Submit>.

6.4 MARKING

Daymarking of obstructions that are 150 m above ground level (AGL) in height or less, such as poles, chimneys, antennas, and cable tower support structures, may consist of alternate bands of aviation orange and white paint. A checkerboard pattern may be used for water tanks, as shown in Figure 6.1. Where a structure is provided with medium or high-intensity white flashing strobe lighting systems that are operated during the day, paint marking of the structure may be omitted.

Figure 6.1—Storage Tank Marking

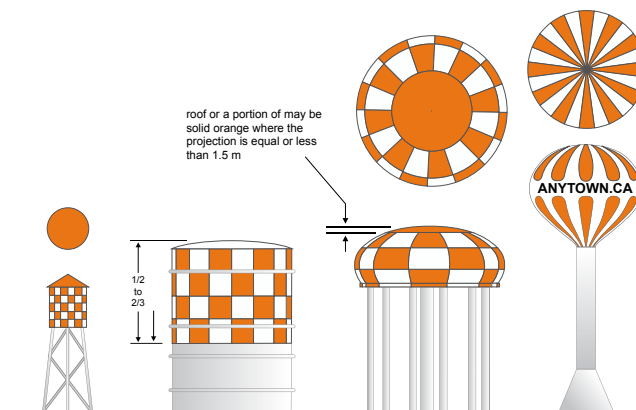

6.5 LIGHTING

Lighting is installed on obstructions in order to warn pilots of a potential collision.

The required intensity for this lighting is based upon an acquisition distance from which the pilot would recognize the lighting as identifying an obstruction, and be able to initiate evasive action to miss the obstruction by at least 600 m. For an aircraft operating at 165 knots indicated airspeed (KIAS), the acquisition distance is 1.90 km. For an aircraft operating between 165 and 250 KIAS, the acquisition distance is 2.4 km.

A variety of lighting systems are used on obstructions. Table 6.1 indicates the characteristics of light units according to their name or designation. Although these designations are similar to those of the Federal Aviation Administration (FAA), the photometric characteristics (intensity distribution) are not necessarily the same.

CL-810 lights are used primarily for night protection on smaller structures and for intermediate lighting on antennas of more than 45 m.

CL-856 lights are used primarily for high structures and day protection on towers where marking may be omitted.

CL-857 lights are used for lighting catenary crossings where marking can be omitted.

CL-864 lights are used for night protection of extensive obstacles, such as wind farms and towers, of more than 45 m.

For CL-865 lights, when operated 24hr/day on towers of less than 150m, paint marking may be omitted.

CL-866 lights are used for white catenary lighting.

CL-885 lights are used for red catenary lighting.

Table 6.1—Light Unit Characteristics

Name	Colour	Intensity	Intensity Value (candelas)	Signal Type	Flash Rate (flashes per min)
CL-810	red	low	32	steady burning	n/a
CL-856	white	high	200 000	flashing	40
CL-857	white	high	100 000	flashing	60
CL-864	red	medium	2 000	flashing	20–40
CL-865	white	medium	20 000	flashing	40
CL-866	white	medium	20 000	flashing	60
CL-885	red	medium	2 000	flashing	60

6.5.1 Rotating Obstruction Light

The majority of flashing obstruction light units are of a strobe (capacitor discharge) design. An exception is one type of CL-865 medium-intensity flashing light, which is of a rotating design, i.e. the light display is produced by rotating lenses. Since this particular light unit might otherwise be mistaken for an aerodrome beacon, colour coding is used to produce a sequenced display of white, white, red, white, white, and red.

Figure 6.2—Rotating Obstruction Light



The rotating type CL-865 also has the same 20 000 candela intensity for nighttime as for daytime operation. The absence of dimming is allowed for two reasons: (1) the specified intensities are minimum requirements; and (2) the rotating characteristic does not produce glare for the pilot.

6.5.2 Tower Configurations

Depending on the height of the towers and other factors, the installation of lights on towers and antennas may vary as shown in Figure 6.3.

Figure 6.3—Configurations of Lighting on Skeletal Structures

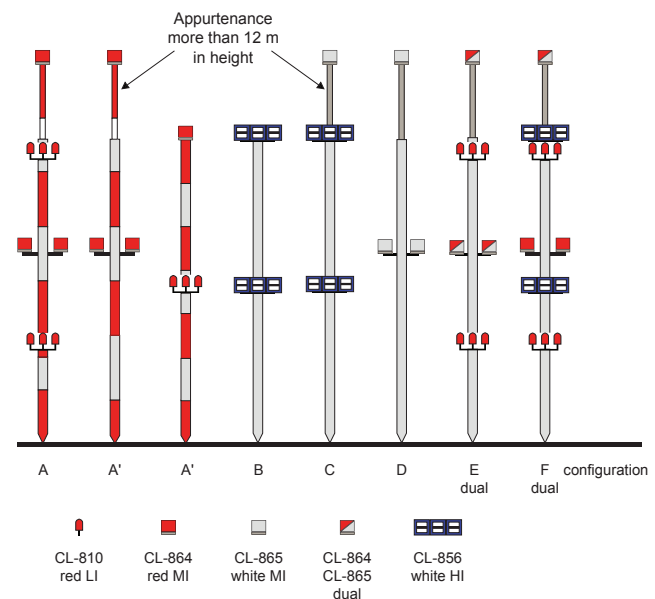

6.6 APPURTENANCES

Where an obstruction is provided with a red obstruction lighting system, any appurtenance 12 m in height will require an obstruction light at the base of the appurtenance. Where such an appurtenance is more than 12 m in height, the light must be installed on the top of the appurtenance. If the appurtenance is not capable of carrying the light unit, the light may be mounted on the top of an adjacent mast.

Where a high-intensity white flashing lighting system is required, appurtenances higher than 12 m in height will require a top-mounted medium-intensity white flashing omnidirectional light unit.

6.7 SUSPENDED CABLE SPAN MARKINGS

Suspended cable spans, such as power line crossings, assessed as being hazardous to air navigation are normally marked with coloured balls suspended from a messenger cable between the tops of the support towers. The support towers are obstruction painted. When painting the support towers is not practical, or when additional warning is necessary, shore markers painted international orange and white will be displayed. In some cases, older marker panels that have not been updated are of a checkerboard design.

An alternative method of marking is to use strobe lights on shore-based cable support towers. Normally three levels of lights are installed as follows: one light unit at the top of the structures to provide 360° coverage; two light units on each structure at the lowest point of the arc of the lowest cable; and two light units at a point midway between the top and bottom levels with 180° coverage. The beams of the middle and lower lights are adjusted so that the signal will be seen from the approach direction on either side of the power line. The lights flash sequentially: middle lights followed by the top lights and then the bottom lights in order to display a “fly up” signal to the pilot. The middle light may be removed in the case of narrow power line sags; in this case the bottom lights will flash first then the top lights will flash in order to display a “fly up” signal to the pilot. When deemed appropriate by an aeronautical study, medium-intensity white flashing omnidirectional lighting systems may be used on supporting structures of suspended cable spans lower than 150 m above ground level (AGL).

Obstruction markings on aerial cables (i.e. marker balls) that define aeronautical hazards are generally placed on the highest line for crossings where there is more than one cable. Obstruction markings can also be installed on crossings under the *Navigation Protection Act*. In this case, the marker balls are placed on the lowest power line and are displayed to water craft as a warning of low clearance between the water and an overhead cable.

In accordance with the foregoing, pilots operating at low levels may expect to find power line crossings marked as either an aeronautical hazard or a navigable water hazard. They may be unmarked if it has been determined by the applicable department or agency that they are neither an aeronautical nor a navigable waters hazard. Pilots operating at low altitudes must be aware of these hazards and exercise extreme caution.

Figure 6.4—Markers for Cable Span

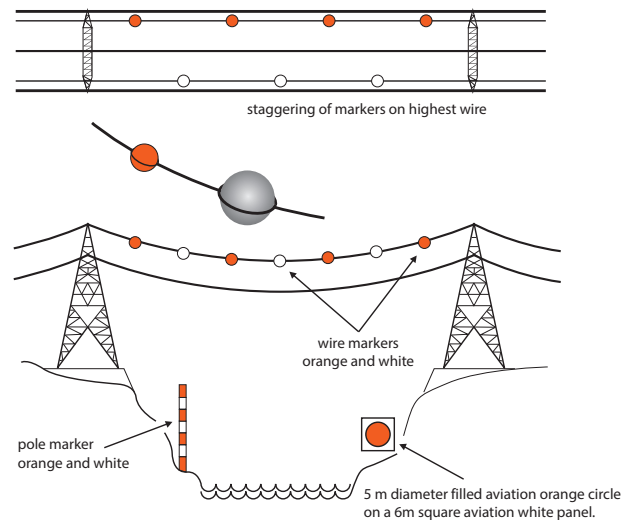

6.8 AIRCRAFT DETECTION SYSTEMS

A technology has been developed so that obstacle lighting is activated only when required to alert pilots who are on a flight path that may lead to a collision with the obstacle. The system addresses public complaints regarding light pollution.

The system uses radar to detect and track aircraft. The potential for collision with an obstacle is determined by the aircraft’s speed and angle of approach. If there is a risk of collision, the lighting turns on and an audio warning (if provided) is broadcast on the very high frequency (VHF) radio. The lighting does not turn on until it is needed by the detected aircraft. Since the system uses radar, its operation is independent of any equipment on board the aircraft (e.g. a transponder).

The obstacle lighting is turned on and the audio warning is emitted approximately 30 s before the aircraft reaches the obstacle. In the case of catenaries, the audio warning will state “POWER LINE, POWER LINE”. For other types of obstructions, a different message will be sent. In some cases, such as those involving wind farms near aerodromes, an audio signal might not be provided, in order to avoid confusing pilots making an approach to landing.

Any questions or comments may be directed to the Transport Canada Flight Standards office in Ottawa (see GEN 1.1.1 for contact information).

7.0 AERODROME LIGHTING

7.1 GENERAL

The lighting facilities available at an aerodrome or airport are described in the *Canada Flight Supplement (CFS)*. Information concerning an aerodrome or airport’s night lighting procedures is included as part of the description of lighting facilities, where routine night lighting procedures are in effect. Where night lighting procedures are not published for an aerodrome or airport, pilots should contact the aerodrome operator concerned and request that the appropriate lights be turned on to facilitate their intended night operations.

7.2 AERODROME BEACON

Many aerodromes are equipped with a flashing white beacon light to assist pilots in locating the aerodrome at night. The aerodrome beacon may be of the rotating or flashing type. The flash frequency of beacons at aerodromes or airports used by aeroplanes is 22 to 26 evenly spaced flashes per minute (fpm) for rotating beacons or 20 to 30 for flashing beacons.

The flash frequency of beacons at aerodromes and heliports used only by helicopters is sequenced to transmit the Morse code letter “H” (in groups of four quick flashes) at the rate of three to four groups per minute.

7.3 MINIMUM NIGHT LIGHTING REQUIREMENTS AT AERODROMES

Section 301.07 of the *Canadian Aviation Regulations* (CARs) requires that any area of land that is to be used as an aerodrome at night shall have fixed (steady) white lights to mark the runway, and fixed red lights to mark unserviceable (hazardous) areas.

Retroreflective markers may be substituted for lights to mark the runway at aerodromes, provided alignment lights are installed (see AGA 7.19). This alternative for night marking of runways, however, is not approved for certified sites.

7.4 UNSERVICEABLE AREA LIGHTING

Unserviceable areas within the manoeuvring area of an aerodrome being used at night are marked by steady burning red lights outlining the perimeter of the unserviceable area(s). Where it is considered necessary in the interest of safety, one or more flashing red lights may be used in addition to the steady red lights.

7.5 APPROACH LIGHTING

The approach lighting systems depicted in the *Canada Flight Supplement* (CFS) include the following:

7.5.1 Non-Precision Approach Runways

Low Intensity Approach Lighting System (LIAL): This system is provided on non-precision approach runways and consists of aviation yellow fixed-intensity twin light units spaced at 60-metre intervals commencing 60 m from the threshold and extending back for a total distance of 900 m (terrain permitting).

Figure 7.1—LIAL

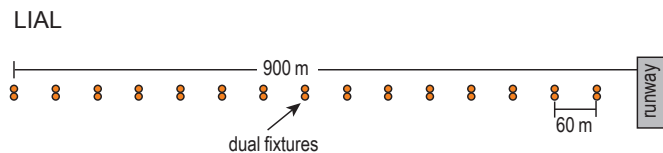

Omnidirectional Approach Lighting System (ODALS): This system is a configuration of seven omnidirectional, variable-intensity, sequenced flashing lights. An ODALS provides circling, offset, and straight-in visual guidance for non-precision approach runways. There are five lights on the extended centreline commencing 90 m from the threshold and spaced 90 m apart

over a total distance of 450 m. Two lights are positioned 12 m to the left and right of the threshold. The system flashes towards the threshold, then the two threshold lights flash in unison; the cycle repeats once per second.

Figure 7.2—ODALS

ODALS

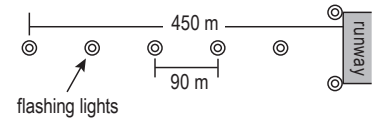

Medium Intensity Approach Lighting System (MALS) or Medium Intensity Approach Lighting System with Sequenced Flashing Lights (MALSF): This system consists of seven barrettes of variable-intensity lights spaced 60 m apart, commencing 60 m from the threshold, over a distance of 420 m. In a MALSF, the three barrettes farthest away from the threshold contain a sequenced flashing light unit. These lights flash sequentially towards the threshold, repeating at two cycles per second.

Figure 7.3—MALSF

MALSF

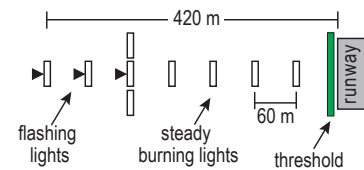

Medium Intensity Approach Lighting System with Runway Alignment Indicator Lights (MALSR): This system consists of variable-intensity approach lights spaced 60 m apart, commencing at 60 m from the threshold, and extending 720 m. This system consists of the following:

- (a) seven barrettes of light over a distance of 420 m;
- (b) one side barrette of light on each side of the centreline barrette at 300 m from the runway threshold; and
- (c) five sequenced flashing lights over the remaining distance of 300 m. These lights flash in sequence towards the threshold at a rate of two cycles per second.

The MALSR has the same configuration as the SSALR, but has lower intensity lights.

Figure 7.4—MALSR

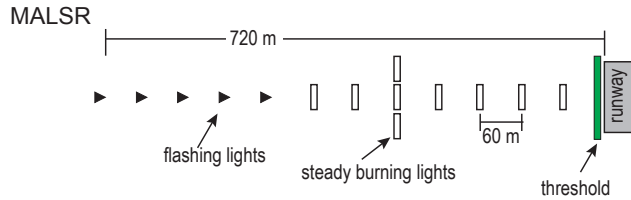

Simplified Short Approach Lighting System (SSALS): This system is the same as MALS (i.e. MALS without the sequenced flashing lights) but high intensity lights are used instead. (See Figure 7.3 for the layout without the sequenced flashing lights.)

7.5.2 Precision Approach Runways

Simplified Short Approach Lighting System with Runway Alignment Indicator Lights (SSALR): This system is the same as the MALSR but high intensity lights are used instead. See Figure 7.4 for the layout.

Approach Lighting System with Sequenced Flashers—CAT II (ALSF-2): This system consists of rows of five white variable-intensity light units placed at longitudinal intervals of 30 m commencing 30 m from the threshold and extending for a total distance of 720 m. In view of the very low decision height associated with CAT II operations, the following additional lights are provided:

- (a) runway threshold (green)
- (b) 150 m distance bar (white with red barrettes)
- (c) side barrettes (red)

Figure 7.5—ALSF-2

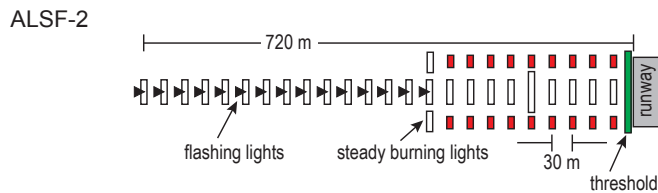

7.6 VISUAL APPROACH SLOPE INDICATOR SYSTEMS (VASIS)

7.6.1 General

VASIS is a generic term referring to different approach slope indicators. Types of VASIS are VASI (visual approach slope indicator), AVASI (abbreviated VASI), PAPI (precision approach path indicator), and APAPI (abbreviated PAPI).

A VASIS consists of a series of lights visible from approximately 4 NM and designed to provide visual indications of the desired approach slope to a runway (usually 3°). At a certified airport, aircraft following the on-slope signal are provided with safe obstruction clearance to a minimum of 6° on either side of the extended runway centreline out to 7.5 km (4.1 NM) from the runway threshold. Newly certified airports are commonly protected up to 8° on each side of the extended runway centreline and up to 15 km (8 NM) from the runway threshold. Exceptions will be noted in the CFS. Descent using VASIS should not be initiated until the aircraft is visually aligned with the runway centreline.

The vertical distance from a pilot’s eyes to the lowest portion of the aircraft in the landing configuration is called the eye-to-wheel height (EWH), and this distance varies from less than 10 ft (3 m) up to 45 ft (14 m) for some wide-bodied aircraft, such as the B-747. Consequently, approach slope indicator systems are related to the EWH for the critical aircraft declared by the airport operator, and they provide safe wheel clearance over the threshold when the pilot is receiving the on-slope indication.

Pilots and/or air operators should ensure that the VASIS type to be used is appropriate to the given aircraft type, based on the EWH group for that aircraft. If this information is not already available in the AFM or other authoritative aircraft manuals (e.g. the flight crew operating manual), the aircraft manufacturer should be contacted.

CAUTION:

Incompatibility between the EWH and the VASIS type could result in decreased terrain clearance margins and, in some cases, even premature contact with terrain (e.g. a CFIT accident).

The current Canadian civil aviation standard for VASIS is the PAPI. Some airports still have the older VASI systems. The VASI and PAPI light units have the same purpose of descent indication with respect to an approach corridor but are arranged in a different pattern, as shown below.

The VASI and PAPI have lights normally situated on the left side of the runway only. When available strip widths preclude the use of a full system, an AVASI or APAPI, consisting of only two light units, may be installed.

Where a PAPI or VASI signal has been harmonized with an electronic vertical guidance signal, it will be for the critical aircraft with a specific EWH group as determined by the airport operator. It is therefore possible for the pilot flying an aircraft type from a different EWH group to see a conflict between the approach vertical guidance signal and the visual (VASI/PAPI) glide slope signal.



7.6.2 Visual Approach Slope Indicator (VASI) V1 and V2 and Abbreviated VASI (AVASI) AV

The VASI (V1 and V2) consists of four light units situated on the left side of the runway in the form of a pair of wing bars (two light units per wing bar), referred to as the upwind and downwind wing bars. Each light unit of a wing bar projects a beam of light. The upper part of the beam shows white while the lower part shows red. When the pilot is:

- (a) above the approach slope, both upwind and downwind bars show white.
- (b) on the approach slope, the upwind bar shows red and the downwind bar shows white.
- (c) below the approach slope, both upwind and downwind bars show red.
- (d) well below the approach slope, the lights of the two wing bars merge into one red signal.

The AVASI (AV) consists of two light units situated on the left side of the runway in the form of a pair of wing bars (one light unit per wing bar). The display is similar to that of a VASI and depends on the position of the pilot's eyes.

Figure 7.6—VASI and AVASI Display

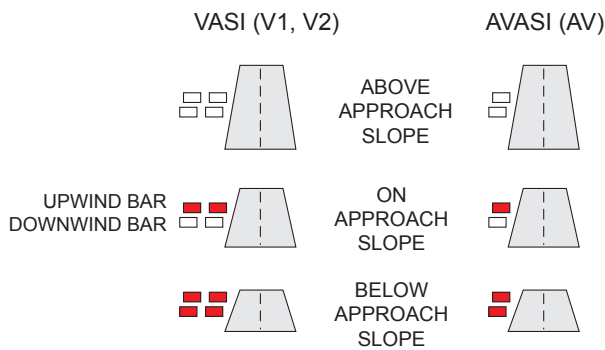

7.6.3 Precision Approach Path Indicator (PAPI) and Abbreviated PAPI (APAPI)

PAPI consists of four light units typically situated on the left side of the runway in the form of a wing bar. When the pilot is:

- (a) well above the approach slope, all four units show white.
- (b) slightly above the approach slope, the one unit nearest the runway edge shows red and the other three show white.
- (c) on or close to the approach slope, the two units nearest the runway edge show red and the two units farthest from the runway edge show white.
- (d) slightly below the approach slope, the three units nearest the runway edge show red and the other shows white.
- (e) well below the approach slope, all four units show red.

APAPI consists of two light units situated on the left side of the runway in the form of a wing bar. When the pilot is:

- (a) above the approach slope, both units show white.

- (b) on or close to the approach slope, the unit nearer to the runway edge shows red and the unit farther from the runway edge shows white.
- (c) below the approach slope, all units show red.

Figure 7.7—PAPI and APAPI Display

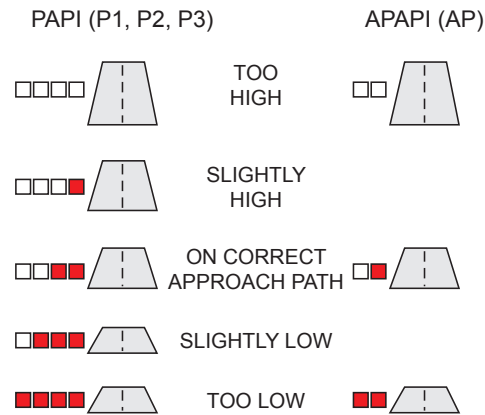

CAUTION:

Lens Contamination—The PAPI/APAPI light box is a sealed design with a front lens or cover glass. When the temperature of the PAPI/APAPI unit lens or cover glass descends below the dew point, frost or condensation may occur depending on the season. Frost or condensation contamination may produce a false signal by mixing the red and white colours of the beam. Under these conditions, the relative intensities of the red and white portions of the beam may cause the mixture to be perceived as predominantly white in colour for a period of time after the PAPI/APAPI is first turned on. Since the mixture may be interpreted as a fly-down signal, the pilot should be aware of other cues (e.g. the runway perspective) so as to avoid descent below the OPS. When the PAPI/APAPI provides a true signal, it should display a crisp transition from white to red as the aircraft descends through the sectors. If contamination is suspected, flight crews are advised to disregard the PAPI/APAPI display.

7.6.4 Categories According to Eye-To-Wheel Height (EWH) in the Approach Configuration

7.6.4.1 General

VASIS are categorized according to the EWH in the approach configuration, as shown in Tables 7.1 and 7.2 below. Where a VASIS is given for a published category, it is intended to be useable by all aircraft within the stated EWH group unless otherwise stated.

NOTE:

The EWH is the vertical distance in-flight of the eye path to the wheel path, as shown in Figure 7.8, and is determined by the approach slope angle and the pitch angle for the maximum certified landing weight at V_{ref} . This should not be confused with

7.7 RUNWAY IDENTIFICATION LIGHTING

7.7.1 Runway Threshold Identification Lights (RTIL)

These are provided at aerodromes where terrain precludes the installation of approach lights, or where unrelated non-aeronautical lights or the lack of daytime contrast reduces the effects of approach lights. When an aerodrome is equipped with RTILs, it is indicated in the CFS by the notation “AS”.

7.7.2 Visual Alignment Guidance System (VAGS)

The VAGS consists of two lights similar to RTILs. However, by means of light beam rotation, the pilot is presented with a sequenced display, as shown in Figure 7.10 below. The display directs the pilot towards the runway/helipad axis, where he or she then sees the lights flash simultaneously.

Figure 7.10—VAGS

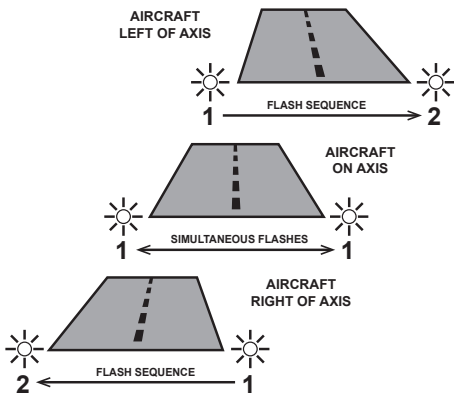

7.8 RUNWAY LIGHTING

A runway on an aerodrome that is used at night shall display two parallel lines of fixed white lights visible for at least 2 mi. to mark take-off and landing areas. These lights are arranged so that:

- (a) the lines of lights or markers are parallel and of equal length and the transverse distance between the lines is equal to the runway width in use during the day;
- (b) the distance between adjacent lights or markers in each line is the same and is not more than 60 m (200 ft);
- (c) each line of lights or markers is not less than 420 m (1 377 ft) in length and contains no fewer than eight lights or markers; and
- (d) each light or marker in a line of lights or markers is situated opposite to a light or marker in the line of lights or markers on the other side of the runway, so that a line connecting them forms a right angle to the centreline of the runway.

For a certified aerodrome, runway lighting may include centreline and touchdown zone lighting depending on runway visibility and approach category.

7.8.1 Runway Edge Lights (REDL)

These are variable-intensity white lights at the runway edges along the full length of the runway spaced at maximum intervals of 60 m, except at intersections with other runways. On some runways, a 600-m section of lights or the last third of the runway at the remote end—whichever is shorter—may show yellow. The units are light in weight and mounted in a frangible manner.

7.8.2 Runway Threshold Lights and Runway End Lights (RENL)

Runway threshold/end indication is provided by green and red light units respectively, in the form of a pair of bars along the threshold on each side of the runway centreline, where there is an ODALS or where no approach lighting is provided. Red shows in the direction of takeoff and green shows in the approach direction.

Where approach lighting other than ODALS is provided, an approach threshold bar that extends across the full width of the runway forms part of the approach lighting configuration. Figure 7.11 shows the different configurations of such lights. RENL are always provided. Runway threshold lights are independent from approach threshold bar lights and are only lit if the approach threshold bar is not lit.

Where MALSR, MALSF or MALS is provided, the green threshold lighting is physically separated from the approach threshold bar due to difference in light intensities and circuitry.

Where SSALR or SSALS is provided, the runway threshold lights form part of the approach threshold bar configuration (opposite the runway end lights).

Where an ALSF-2 is provided, the green threshold lighting is extended farther as wing bars to each side of the runway.

Figure 7.11—Runway Threshold and End Lights

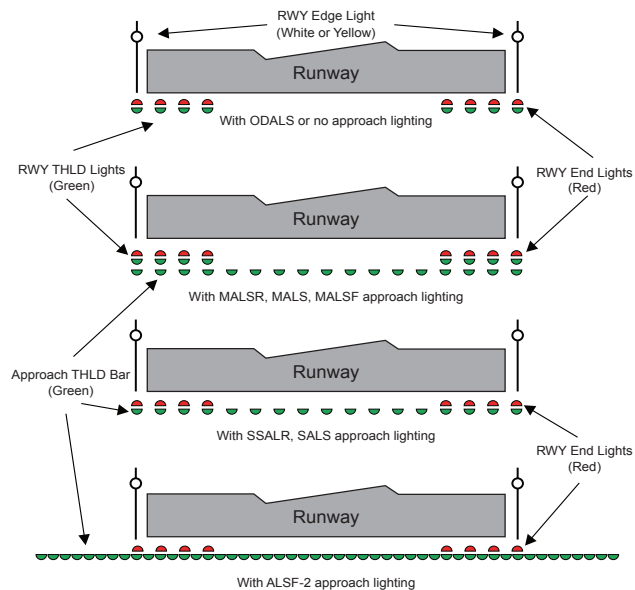

7.8.3 Displaced Threshold Lighting

Where runway thresholds have been displaced from the beginning of the runway, the runway threshold lights and the approach threshold bar are displaced accordingly, using inset lights for approach threshold bars and wing bar lights for runway threshold lights, as follows:

Figure 7.12—Displaced Threshold Lighting

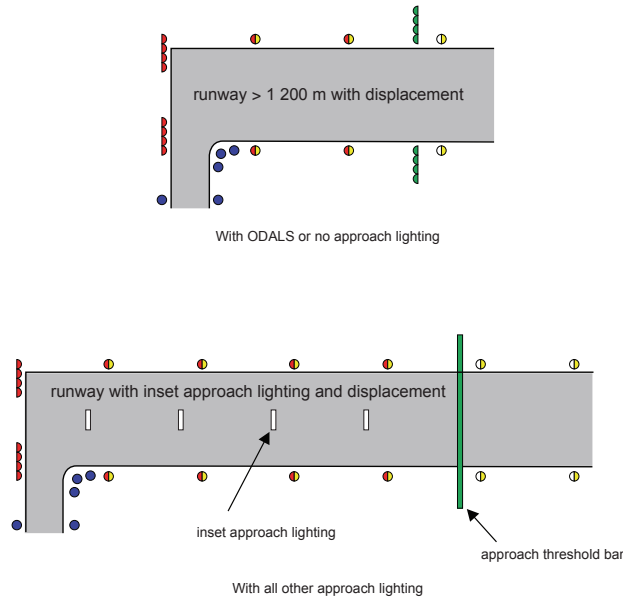

7.8.4 Runway Centreline Lighting

Runway centreline lighting is provided on CAT II and CAT III runways. It consists of lights installed on the runway surface spaced at intervals of 15 m. The lights leading in the take-off or landing direction are variable white from the threshold to 900 m from the runway end; alternate red and variable white from 900 m to 300 m from the runway end; and red from 300 m to the end of the runway.

7.8.5 Runway Touchdown Zone Lighting

Touchdown zone variable intensity white lights are provided on CAT II and CAT III instrument runways. They consist of barrettes of three inset lights disposed on either side of the runway centreline, spaced at 30-m intervals commencing 30 m from the threshold. They extend from the threshold for a distance of 900 m down the runway. The lights are unidirectional, showing in the direction of approach to landing.

Figure 7.13—Runway Touchdown Zone Lighting

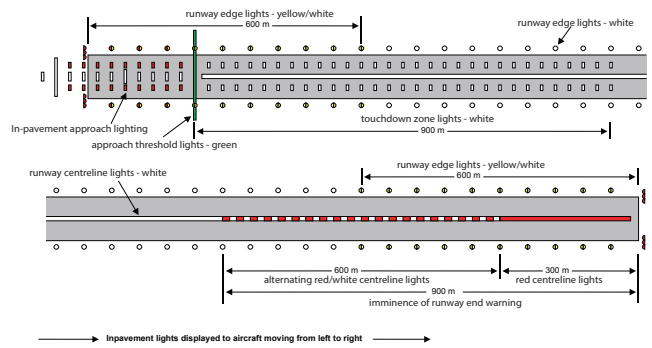

7.9 RAPID-EXIT TAXIWAY INDICATOR LIGHTS (RETIL)

Rapid-exit taxiway indicator lights (RETIL) provide pilots with distance-to-go information to the nearest rapid-exit taxiway on the runway. RETIL are fixed unidirectional yellow lights located on the runway on the same side of the runway centreline as the associated rapid-exit taxiway, in the configuration shown in Figure 7.14.

Figure 7.14—Rapid-Exit Taxiway Indicator Lights

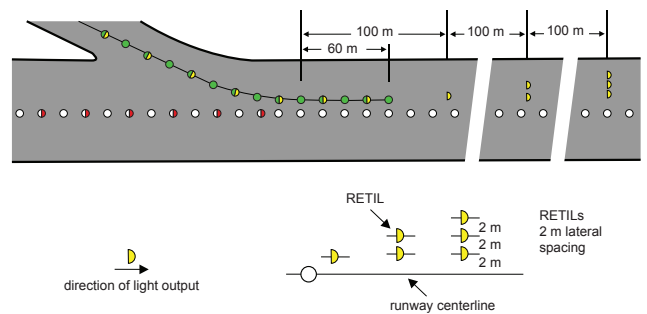

7.10 TAXIWAY LIGHTING

7.10.1 Taxiway Edge Lights

Taxiway edge lights are blue in colour and are spaced at maximum intervals of 60 m. Where a taxiway intersects another taxiway or a runway, two adjacent blue lights are placed at each side of the taxiway where no fillet or curve is provided. To facilitate the identification of the taxiway entrance for an aircraft on departure and arriving from the apron, the intersection of an apron with a taxiway is indicated by two adjacent yellow lights at taxiway/apron corners.

AGGA

7.10.2 Taxiway Centreline Lights

Taxiway centreline lights are green in colour and are installed on the taxiway surface. They are spaced at 15-m intervals with less spacing on taxiway curves. Taxiway centreline lights on an exit taxiway show alternate green and yellow from their beginning near the runway centreline to the outer perimeter of the ILS critical/sensitive area or the runway-holding position, whichever is farther from the runway; thereafter, all lights show green.

7.10.3 Stop Bars

A stop bar is provided at every runway-holding position serving a runway intended to be used in visibility conditions below RVR 1200 (¼ SM). Stop bars are located across the taxiway at the desired stopping point for traffic and consist of lights spaced at intervals of 3 m across the taxiway. They show red in the intended direction of approach to the intersection or runway-holding position.

Where the stop bar is co-located with taxiway centreline lighting, a 90-m segment of the taxiway centreline lighting beyond the stop bar is turned off when the stop bar is illuminated. The stop bar is illuminated again after a timed duration or by means of sensors installed on the taxiway.

CAUTION:

Pilots and vehicle drivers are reminded of the following:

- (a) An aircraft or vehicle shall never cross an illuminated stop bar, even with clearance from ATC.
- (b) ATC switching the illuminated stop bar off does not constitute a clearance to enter the runway.
- (c) An aircraft or vehicle shall only proceed past a stop bar when ATC provides the appropriate verbal clearance AND switches the illuminated stop bar off.
- (d) If ATC issues a clearance to enter the runway and the stop bar remains on:
 - (i) DO NOT PROCEED;
 - (ii) advise ATC that the stop bar is still on; and
 - (iii) wait for further clearance.

Figure 7.15—Stop Bar Lighting

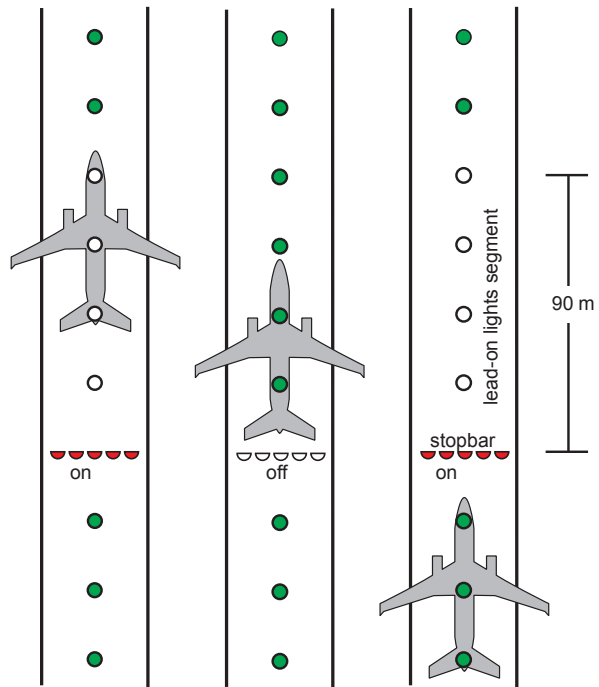

7.11 RUNWAY GUARD LIGHTS

Runway guard lights are provided at each taxiway/runway intersection to enhance the conspicuity of the holding position for taxiways supporting runway operations below a visibility value of runway visual range (RVR) 2600 (½ SM). They consist of yellow unidirectional lights that are visible to the pilot of an aircraft taxiing to the holding position, but their configuration may vary:

- (a) They can consist of a series of lights spaced at intervals of 3 m across the taxiway. Where this is the case, the adjacent lights illuminate alternately and even lights illuminate alternately with odd lights.
- (b) They can consist of two pairs of lights, one on each side of the taxiway adjacent to the hold line. Where this is the case, the lights in each unit illuminate alternately.

7.12 HELIPORT LIGHTING

7.12.1 Touchdown and Lift-Off Area (TLOF) Lighting

Where a heliport is used at night, the perimeter of the TLOF may be lighted by yellow perimeter lights or by floodlighting.

Yellow perimeter lights: Where the TLOF is circular, no fewer than eight yellow lights are used to mark the perimeter. In a rectangular layout, the perimeter is marked by a minimum of four yellow lights on each side, with a light at each corner.

Floodlighting: When provided, the floodlighting will illuminate the TLOF such that the perimeter marking of the TLOF is visible. Floodlight units will be located beyond the perimeter of the FATO.

NOTE: Perimeter lighting or reflective tape may be used in addition to floodlighting.

7.12.2 Final Approach and Take-Off (FATO) Lighting

A FATO perimeter is marked by white or green lights in the same configuration as TLOF perimeter lighting (see AGA 7.12.1). Where a TLOF is not located within a FATO, the aiming point will be defined by at least seven red aeronautical ground lights located on the triangular marking.

FATO or TLOF perimeter lights may be LEDs. Consult the CFS for verification of lighting type.

CAUTION: Heliports using LED lighting systems may not be visible when certain NVIS equipment is employed. This is an operational limitation of the NVIS equipment, as the purpose of heliport lighting is to be viewed by the naked eye.

Candela values for heliport lighting systems are detailed in Figure 5-11 of ICAO Annex 14, Volume II.

Figure 7.16—Examples of TLOF Lighting

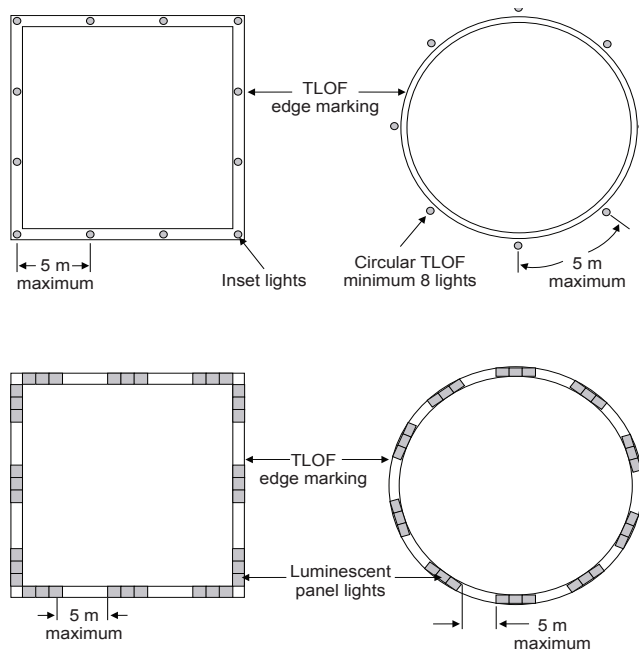
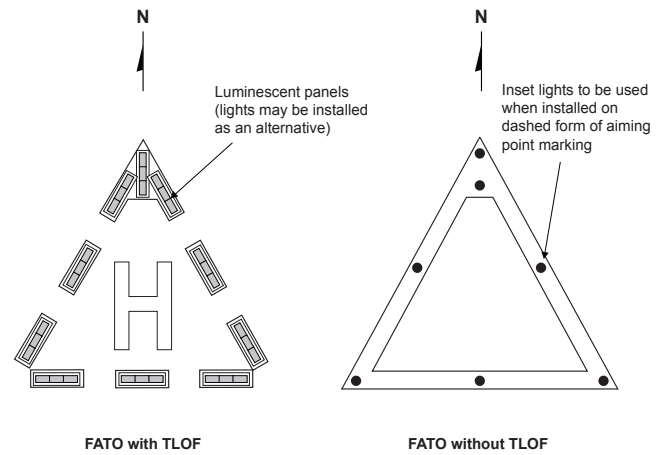

Figure 7.17—FATO and Aiming Point Lighting



7.12.3 Approach/Take-Off Direction Lights

At some heliports, where it is necessary to follow preferred approach and take-off paths to avoid obstructions or noise-sensitive areas, the direction of the preferred approach and take-off routes will be indicated by a row of five yellow fixed omnidirectional lights outside the FATO.

Figure 7.18—Maximum Mounting Height for TLOF, FATO, and Approach/Take-Off Direction Lights

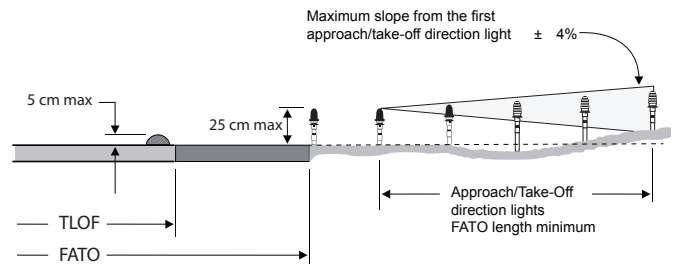

7.13 EMERGENCY LIGHTING

Airports with Category (CAT) I, II, and III precision approaches in Canada are equipped with a secondary power system for visual aids lighting. This system is normally capable of assuming the electrical load within approximately 15 s for CAT I operations, and within 1 s for CAT II and III operations.

7.14 AIRCRAFT RADIO CONTROL OF AERODROME LIGHTING (ARCAL)

Aircraft radio control of aerodrome lighting (ARCAL) systems are becoming more prevalent as a means of conserving energy, especially at aerodromes not staffed on a continuous basis or at which it is not practicable to install a land line to a nearby flight service station (FSS). Aside from obstacle lights, some or all of the aerodrome lighting may be radio-controlled.

Control of the lights should be possible when aircraft are within 15 NM of the aerodrome. The frequency range is 118 to 136 MHz.

The system is activated via the aircraft very high frequency (VHF) transmitter and by pressing the push-to-talk button on the microphone a given number of times within a specified number of seconds. Each activation will start a timer to illuminate the lights for a period of approximately 15 min. The timing cycle may be restarted at any time by repeating the specified keying sequence. It should be noted that ARCAL Type K runway threshold identification lights (RTIL) (code AS) can be turned off by keying the microphone three times on the appropriate frequency. The code for the intensity and the lighting period varies for each installation. Consequently, the *Canada Flight Supplement* (CFS) must be consulted for each installation.

NOTE:

Pilots are advised to key the activating sequence when beginning their approach, even if the aerodrome or airport lighting is on. This will restart the timing cycle so that the full 15-min cycle is available for their approach.

7.15 RETROREFLECTIVE MARKERS

Some aerodromes may use retroreflective markers in place of lights to mark the edges of runways or helipads. These retroreflective markers are approved for use on runways at registered aerodromes only; however, they may be used as a substitute for edge lighting on taxiways or apron areas at some certified airports.

Retroreflective markers are to be positioned in the same manner as runway lighting described earlier in this chapter. Therefore, when the aircraft is lined up on final approach, retroreflective markers will provide the pilot with the same visual representation given by normal runway lighting. A fixed white light or strobe light shall be installed at each end of the runway to assist pilots in locating the aerodrome and aligning the aircraft with the runway. Similarly, retroreflective markers at heliports are to be positioned in the same pattern that is prescribed for helipad edge lighting.

The approved standard for retroreflective markers requires that they be capable of reflecting the aircraft landing lights so that they are visible from a distance of 2 NM. Pilots are cautioned that the reflective capabilities of retroreflective markers are greatly affected by the condition of the aircraft landing lights, the prevailing visibility, and other obscuring weather phenomena. Therefore, as part of pre-flight planning to an aerodrome that uses retroreflective markers, pilots should exercise extra caution in checking the serviceability of their aircraft landing lights and making provision for an alternate airport with lighting in case of an aircraft landing light failure.

8.0 AIRCRAFT RESCUE AND FIRE FIGHTING (ARFF)

8.1 GENERAL

Aircraft rescue and firefighting (ARFF) service is provided at some airports in accordance with the criteria stated in *Canadian Aviation Regulation* (CAR) 303. The primary responsibility of an ARFF service is to provide a fire-free egress route for the evacuation of passengers and crew following an aircraft accident.

8.2 AIRCRAFT RESCUE AND FIRE FIGHTING (ARFF) HOURS OF AVAILABILITY

Aerodromes or airports that provide aircraft rescue and firefighting (ARFF) publish the hours during which an ARFF service is operated in the *Canada Flight Supplement* (CFS) under the ARFF annotation. If there are no published hours next to the ARFF critical category number, this means 24-hour service is offered.

8.3 CLASSIFICATION SYSTEM

Table 8.1 identifies the critical category for firefighting as it relates to the aircraft size, the quantities of water and complementary extinguishing agents, the minimum number of aircraft rescue and firefighting (ARFF) vehicles, and the total discharge capacity. For ease of interpretation, the table is a combination of the two tables found under *Canadian Aviation Regulation* (CAR) 303.

Table 8.1—Classification for ARFF Purposes

Aircraft Category	Aircraft Overall Length	Maximum Fuselage Width (m)	Quantity of Water (L)	Quantity of Complementary Agents (kg)	Minimum Number of Aircraft Firefighting Vehicles	Total Discharge Capacity (L/min)
1	less than 9 m	2	230	45	1	230
2	at least 9 m but less than 12 m	2	670	90	1	550
3	at least 12 m but less than 18 m	3	1 200	135	1	900
4	at least 18 m but less than 24 m	4	2 400	135	1	1 800
5	at least 24 m but less than 28 m	4	5 400	180	1	3 000
6	at least 28 m but less than 39 m	5	7 900	225	2	4 000
7	at least 39 m but less than 49 m	5	12 100	225	2	5 300
8	at least 49 m but less than 61 m	7	18 200	450	3	7 200
9	at least 61 m but less than 76 m	7	24 300	450	3	9 000
10	at least 76 m	8	32 300	450	3	11 200



8.4 AIRCRAFT RESCUE AND FIRE FIGHTING (ARFF) STANDBY REQUEST

Local standby means the level of response when an aircraft has, or is suspected to have, an operational defect. This defect could compromise a safe landing.

Full emergency standby means the level of response when an aircraft has, or is suspected to have, an operational defect that affects normal flight operations to the extent that there is possibility of an accident.

When informed that an emergency has been declared by a pilot, the airport aircraft rescue and firefighting (ARFF) unit will take up emergency positions adjacent to the landing runway and stand by to provide assistance. Once response to an emergency situation has been initiated, the ARFF unit will remain at the increased state of alert until informed that the pilot-in-command has terminated the emergency. After the landing, ARFF will intervene as necessary and, unless the pilot-in-command authorizes their release, escort the aircraft to the apron and remain in position until all engines are shut down.

For an adequate response on the part of the ARFF unit, a pilot request to “stand by in the fire hall” is not appropriate. Pilots are reminded, however, that the ARFF unit will terminate their state of alert when informed by the pilot that the emergency situation no longer exists.

8.5 AIRCRAFT RESCUE AND FIRE FIGHTING (ARFF) DISCREET COMMUNICATION

The capability to communicate on a discreet frequency is normally available at airports that provide aircraft rescue and firefighting (ARFF) services.

9.0 AIRCRAFT ARRESTING SYSTEMS

9.1 ENGINEERED MATERIAL ARRESTING SYSTEMS (EMAS)

The engineered material arresting system (EMAS) is an arresting system designed for transport category aeroplanes in the event of a runway overrun. An EMAS bed is designed to stop an overrunning aeroplane by exerting predictable deceleration forces on its landing gear as the EMAS material crushes.

9.1.1 System Description

The strength of the arrester bed is designed to reduce the aeroplane’s speed without leading to structural failure of the landing gear. The beds are made up of a grouping of crushable cellular concrete blocks that will reliably and predictably be crushed under the weight of an aeroplane.

To arrest an aeroplane overrunning a runway end, EMAS beds are placed beyond the end of a runway and in alignment with the extended runway centreline.

Figure 9.1—Photograph of an EMAS Installation



(The EMAS bed is the grey area under the yellow chevrons)

9.1.2 System Depiction

The aerodrome sketch will show the location and dimensions of the EMAS beds. In the example below, the EMAS bed is shown as an outlined box with diagonal lines running through it. The dimensions are provided in feet.

Figure 9.2—EMAS Depiction on an Aerodrome Sketch

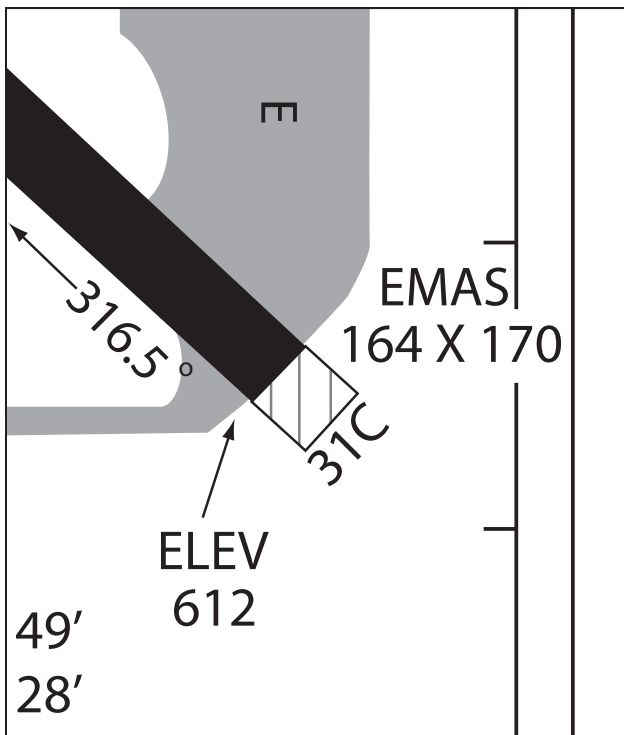

9.1.3 Pilot Considerations for Engagement

Prior to using a runway, pilots should be aware of the presence of an EMAS bed. Pilots should review the aerodrome sketch and other aerodrome information to determine whether the runway that they will be using is equipped with an EMAS.

If, during the take-off or landing phase, a pilot determines that the aeroplane will overrun the runway end and enter the EMAS, the following procedure should be followed:

- (a) Continue to follow the rejected-takeoff procedures or, in the case of landing, the maximum-braking procedures outlined in the AFM, regardless of the aeroplane’s speed upon overrunning the runway.
- (b) Continue straight ahead—do not veer left or right. The EMAS’s stopping capability is maximized when all of the aeroplane’s landing gears enter the bed. Veering to the side may result in the aeroplane missing the bed altogether or having only one set of wheels enter the bed with reduced effectiveness. The quality of deceleration will be best within the confines of the bed. The further the aeroplane travels into the bed, and into deeper concrete, the greater the deceleration.
- (c) Do not take any action—the arrester bed is a passive system, similar to other traditional arresting systems such as cables, chains, and aircraft netting.
- (d) Do not attempt to taxi or otherwise move the aeroplane once it has stopped.
- (e) Use standard aircraft emergency ground egress procedures, should an emergency egress be required. Where the surface of the bed has been breached, the loose material will crumble underfoot. During egress, it is important to note that the two sides and the back of the arrester bed have built-in continuous steps built in to help provide easy access for ARFF vehicles and to enable passengers to step off the bed safely.
- (f) Use slides or aircraft stairs to allow passengers to deplane after an EMAS arrestment, since the EMAS bed will not provide a stable base for the air stairs.

9.2 MILITARY AIRCRAFT ARRESTING SYSTEMS

9.2.1 Background

Some civil airports and military aerodromes are equipped with aircraft arresting systems. An aircraft arresting system usually consists of two sets of gear, called energy absorbers, with one located on each side of the runway, normally approximately 460 m from the threshold. These energy absorbers are interconnected by an arrester cable, which is attached to a nylon tape that is wound onto a tape storage drum (reel) on each energy absorber. To keep the energy absorbers away from the edge of the runway, runway edge sheaves are located next to the runway edge. The runway edge sheaves act as a guide (pulley) for the tape and have sloped sides to permit an aircraft to roll over them.

When the tailhook of a fighter aircraft engages the cable, the tape storage drums start to turn. The energy absorbers apply a braking force to the storage drums, which in turn slows the aircraft and brings it to a stop.

9.2.2 Markings

For identification, yellow circles are painted across the runway at the location of the aircraft arrester cable. A lighted sign with a yellow circle is located beside the runway to mark the location during darkness.

9.2.3 Operations

At civil airports, civil aviation operations will not be permitted while the arrester cable is deployed across the runway. At military aerodromes, civil aeroplane operations may be permitted with the arrester cable deployed across the runway.

9.2.4 Damage Hazards

Cables: Pilots are advised to avoid crossing the aircraft arrester cable at speeds in excess of 10 mph because a wave action may develop in the cable, which could damage the aircraft. This is particularly important for nose-wheel aircraft with wheel fairings or minimal propeller or undercarriage-door clearance. Tail-wheel aircraft may also sustain damage if the tail wheel engages the cable.

Runway edge sheaves: The runway edge sheaves are above grade and located next to the runway edge, on the runway shoulder. The two sides perpendicular to the runway are sloped, but the other two sides, parallel to the runway, are vertical. The runway edge sheaves are not frangible and may cause damage to aeroplanes that contact or roll over them.

Energy absorbers: The energy absorbers are normally located beside the graded area of the runway strip (at a distance greater than 61 m from the runway centreline). The energy absorbers are not frangible and will cause damage to aeroplanes that come into contact with them.

9.2.5 Information for Pilots

Pilots will normally be advised of the status of the arrester cable through ATIS or by ATC. The presence of an aircraft arresting system should be included in the RWY DATA entry of the CFS for the aerodromes. The location of an aircraft arresting system should also be depicted on the aerodrome sketch.

10.0 AIRPORT COLLABORATIVE DECISION MAKING (A-CDM)

10.1 INTRODUCTION

Airport Collaborative Decision Making (A-CDM) is a method for improving the predictability of airport operations, resulting in the more efficient use of available resources and a better passenger experience. A-CDM has been in use for some years in various parts of the world and its benefits have been demonstrated.

A-CDM requires the partners involved in the operation of the airport to exchange certain information that meets prescribed levels of quality and timeliness. Furthermore, aircraft operations will be subject to defined A-CDM procedures. Adherence to these procedures is usually mandatory for most aircraft operators, unless a specific exemption applies.

10.2 OPERATIONAL CONCEPT

One of the objectives of Airport Collaborative Decision Making (A-CDM) is to make aircraft turnaround more predictable and create an efficient outbound flow of traffic. This is achieved by requiring a reliable and accurate Target Off-Block Time (TOBT) for each flight. This TOBT is then used to set up an optimal pushback and start-up sequence that considers all applicable constraints, like de-icing and possible air traffic flow management restrictions.

Operators and their designated representatives are responsible for keeping the TOBT up to date by providing updates as necessary. The flight crew is responsible for operating the aircraft, taking the Target Start-Up Approval Time (TSAT) into account. Failure to comply with these responsibilities will usually result in an operational penalty.

More details about a typical A-CDM operation can be found in the *A-CDM Operations Manual – YYZ Edition*, available from the Greater Toronto Airports Authority at <http://torontopearson.com/acdm/>.

10.3 TERMS

The following terms and abbreviations are generally used with Airport Collaborative Decision Making (A-CDM):

Table 10.1—Terms and Abbreviations Used With A-CDM

Term	Definition
Appropriate radio frequency	The radio frequency that a flight crew must use to contact the Apron Management Unit (AMU) or other air traffic services (ATS) unit as part of an A CDM procedure.
Calculated take off time (CTOT)	The time calculated and issued by the air navigation service provider that indicates when an aircraft should be airborne if it is to meet the constraints arising from the applicable Traffic Management Initiatives (TMIs).
Commercial air transport operation	An aircraft operation involving the transport of passengers, cargo, or mail for remuneration or hire.
Designated representative	A person or organization authorized by an operator to act and perform tasks on its behalf within the constraints of their representation agreement.
Estimated off-block time (EOBT)	The estimated time at which the aircraft will start movement associated with departure. Note: This is the time shown in Item 13 of the flight plan.
Flight crew member	A licensed crew member charged with duties essential to the operation of an aircraft during a flight duty period.
Flight plan	Specified information provided to ATS units, relative to an intended flight or portion of a flight of an aircraft.
General aviation (GA) operation	An aircraft operation other than a commercial air transport operation. GA operations include business aviation (BA) operations.
Ground handler	An organization offering the ground handling services that an aircraft needs for the period during which it is on the ground.
HMI	Human-Machine Interface
Minimum turnaround time (MTTT)	The minimum amount of time agreed upon with an operator or ground handler for a specified flight or aircraft type.
Operator	The person, organization, or enterprise engaged in or offering to engage in an aircraft operation.
Pilot-in-command (PIC)	The pilot designated by the operator, or, in the case of GA, the owner, as being in command and charged with the safe conduct of a flight.

Term	Definition
Scheduled off-block time (SOBT)	The time that an aircraft is scheduled to depart from its parking position. Note: SOBT is the coordinated airport slot.
Target off-block time (TOBT)	The time at which an operator or ground handler estimates that an aircraft will be ready, with all doors closed, the boarding bridge removed, and a pushback vehicle available and ready to start up/ push back immediately upon receiving clearance from the AMU. Note: TOBT is equivalent to estimated time of departure (ETD) as used by operators and ground handlers.
Target start-up approval time (TSAT)	The time at which an aircraft can expect to receive start-up/ pushback approval. The TSAT may be equal to the TOBT.
Target take off time (TTOY)	The time at which an aircraft is expected to be airborne based on its TSAT and on the time it takes to taxi to the assigned runway.

10.4 SCOPE OF APPLICABILITY

Airport Collaborative Decision Making (A-CDM) procedures are normally mandatory for all flights operated as commercial air transport or general aviation (GA) operations. Depending on the airport, helicopters and flights identified by any one of the following designators in Item 18 of their flight plan, or by any other agreed-upon means that may be applicable, are sometimes exempt from adhering to A-CDM procedures:

Table 10.2—Operations Exempted From A-CDM Procedures

STS/FFR	Fire fighting
STS/HEAD	Flight with Head of State status
STS/HOSP	Flight on an actual medical mission
STS/MEDEVAC	Flight operated for life-critical medical emergency evacuation
STS/SAR	Flight engaged in a search and rescue mission
STS/STATE	Flight engaged in military, customs, or police services
STS/FLTCK	Aircraft performing NAVAID flight check

Any exemptions would be granted based on the type of mission an aircraft is engaged in and not on the identity of the operator.

10.5 AIRPORT COLLABORATIVE DECISION MAKING (A-CDM) PROCEDURES

Airport Collaborative Decision Making (A-CDM) procedures generally fall into the following three categories:

- (a) Commercial Air Transport Operations—Procedures for Operators and Handling Agents
- (b) Commercial Air Transport Operations—Flight Crew Procedures
- (c) General and Business Aviation Operations—Air Operator Procedures

10.5.1 Commercial Air Transport Operations — Procedures for Operators and Handling Agents

10.5.1.1 Requirement for All Flights to Have a Current Target Off-Block Time (TOBT)

The TOBT is used to indicate when the aircraft will be ready to push back and start its engines. The initial TOBT is usually obtained by the A-CDM system from one of the following sources:

- (a) Estimated time of departure (ETD) provided by an operator via the appropriate communications channel;
- (b) EOBT from the flight plan; or
- (c) SOBT from the airport coordinated schedule data held by the GTAA.

10.5.1.2 Preferred Way of Providing the Target Off-Block Time (TOBT)

Operators are reminded that using the SOBT may result in an inaccurate TOBT. It is therefore highly recommended that they explore options for providing the ETD via the appropriate communications channel. This can be normally be done by contacting the Manager of Operations, Airport Flow, who typically serves as the single point of contact for all A-CDM-related matters.

10.5.1.3 Access to the Target Off-Block Time (TOBT)

The TOBT will be shown and accessible via the A-CDM application and the A-CDM HMI (such as a web portal) as soon as it is set in the A-CDM system.

10.5.1.4 Pre-Departure Sequencing — Target Start-Up Approval Time (TSAT) Generation

Based on the TOBT, a TSAT is generated by the A-CDM system for every flight. The TSAT is used to indicate the sequence in which aircraft can expect to receive pushback and start-up approval, ensuring an optimal flow of traffic to the assigned runways. An update to the TOBT will always result in the recalculation of the TSAT. However, this may not always result in a different TSAT or position in the sequence for the flight concerned.

Any applicable constraints, like the CTOT, resulting from TMIs, taxi times, and possible de-icing time are considered in the

calculation of the TSAT to ensure that such constraints are always met.

10.5.1.5 Access to the Target Start-Up Approval Time (TSAT)

The TSAT will be shown in the A-CDM system via the A-CDM application and the A-CDM HMI as soon as stand and runway information are both available in the A-CDM system.

10.5.1.6 Target Start-Up Approval Time (TSAT) Swapping

An operator or handling agent (as applicable) may be able to swap the TSATs between flights of its own operator family if a given flight is delayed or if a reduction of the waiting time for a flight is desirable. Eligible flights are identified as such on the A-CDM system HMI.

10.5.1.7 The Importance of Updating the Target Off-Block Time (TOBT)

Operators and ground handlers (as appropriate) are responsible for updating the TOBT if there is a difference of +/- 5 minutes compared to the initial or previously updated TOBT. Failing to update the TOBT will result in a TSAT that is no longer operationally correct, and this, in turn, may cause the flight to be subject to unnecessary delay.

10.5.1.8 Target Off-Block Time (TOBT) Update Limitations

The TOBT can normally be updated as many times as necessary until 10 minutes prior to the TOBT. Thereafter, only two more updates are possible. Should a third update be necessary, the operator or handling agent will likely need to contact the Manager of Operations, Airport Flow, for further instructions.

10.5.1.9 Methods for Updating the Target Off-Block Time (TOBT)

The TOBT may be updated via any of the available systems providing access to it.

10.5.2 Commercial Air Transport Operations — Flight Crew Procedures

10.5.2.1 Target Off-Block Time (TOBT) and Target Start-Up Approval Time (TSAT) Delivery Channels

Several channels are often provided for the delivery of the TOBT and TSAT to the flight crew. Operators are free to use any available channel. The following channels are examples:

- (a) Advanced Visual Docking Guidance System (AVDGS), where available.
- (b) Any specific means of communication that may exist between the operator or ground handler and the flight crew. This means of communication may be shared with other operational communications.

- (c) An A-CDM web portal.

10.5.2.2 Access to the Target Off-Block Time (TOBT)

The TOBT will be displayed for the flight crew on all channels as soon as it is set in the A-CDM system.

10.5.2.3 Access to the Target Start-Up Approval Time (TSAT)

The TSAT will be displayed for the flight crew on all channels except the AVDGS as soon as it is set in the A-CDM system. It is expected that the TSAT will be displayed for the flight crew on the AVDGS as follows:

- (a) 10 minutes before TOBT; or
- (b) 20 minutes before TOBT if the TSAT is later than the TOBT by 20 minutes or more (as may be the case due to TMIs).

10.5.2.4 Information Related to Airport Collaborative Decision Making (A-CDM) on the Advanced Visual Docking Guidance System (AVDGS)

The information displayed on the AVDGS depends on the operating mode of the A-CDM system, such as:

- (a) Traditional Ramp Information Display (e.g. ETD) = A-CDM is not running or A-CDM procedures have been suspended; or
- (b) TOBT + time or TOBT + time and TSAT + time = A-CDM is running.

10.5.2.5 Call Ready Procedure

The flight crew usually must call the Apron Coordinator on the published radio frequency for the airport at TOBT +/- 5 minutes to confirm that the flight is ready as defined for the TOBT and state the location “gate.” Thereafter, the crew will need to change to the appropriate radio frequency and monitor it for pushback and start-up approval.

If the flight crew fails to call within the specified time window, it will be assumed that the TOBT is no longer valid and the corresponding TSAT will be removed from the sequence. The operator or ground handler will need to provide a new TOBT for a new TSAT to be generated. This may result in a substantial delay for the flight concerned.

10.5.2.6 Procedures for Extended Times Between Target Off-Block Time (TOBT) and Target Start-Up Approval Time (TSAT)

The time difference between the TOBT and the TSAT assigned to the flight may be substantial. Airports usually have a policy for aircraft to stay at the gate until the assigned TSAT time. In cases where the gate is required for another flight, or on the specific request of the operator or ground handler, the aircraft concerned could be relocated to a waiting area.

10.5.2.7 Airport Collaborative Decision Making (A-CDM)-Imposed Waiting Time and On-Time Performance

Traditionally, on-time performance (OTP) is measured by the point in time when the aircraft releases the brakes and is ready for movement associated with departure. If an aircraft waits at the stand for its TSAT, the time between TOBT and TSAT might be counted as a departure delay, adversely impacting the air operator's OTP. It is recommended that air operators implement procedures whereby the time at which the flight crew makes the ready call is considered as the reference for OTP and any waiting time after the TOBT is met can be successfully ignored.

10.5.2.8 Pushback / Start-Up Approval

Depending on the airport, flight crews might expect pushback instructions and start-up approval to be issued on the appropriate radio frequency by the AMU at TSAT +/- 5 minutes without a need for the flight crew to make an additional call.

If the pushback and start-up process does not commence within 2 minutes of the time the approval was issued, the flight crew must call the AMU on the appropriate radio frequency, explain the situation, and request guidance on how to proceed. If this call is omitted, it will be assumed that the TSAT is no longer valid, and it will be removed from the sequence. The operator or ground handler will need to provide a new TOBT for a new TSAT to be generated. This may result in a substantial delay for the flight concerned.

If the pushback and start-up process is interrupted for any reason after the aircraft has cleared the stand area or if the start-up process is expected to take longer than normal, the flight crew must call the AMU on the appropriate radio frequency, explain the situation, and request guidance on how to proceed.

Flight crews are reminded that the actual order of pushback and start-up approval depends on the operational decisions of the AMU and hence, a difference may exist between the system-generated sequence and the sequence as established by the AMU. However, even after a manual intervention, any applicable constraints, like CTOT, would be met by the modified sequence.

10.5.2.9 Flight Crew Concerns About Meeting Constraints

All functions of an A-CDM system are designed to ensure that applicable constraints, most importantly those resulting from TMIs, are always fully met. For example, the TSAT is calculated taking all applicable constraints into account, and if duly observed by the flight crew, the runway slot (CTOT) allocated to the flight will not be missed.

Nevertheless, if flight crew members estimate that a TSAT assigned to them and their applicable CTOT are not compatible, they should contact their operator or ground handler to resolve the issue via the Manager of Operations, Airport Flow.

10.5.2.10 De-icing Operations

The need for de-icing has a substantial impact on standard A-CDM procedures, in particular the extended taxi times needed to account for the duration of the de-icing operation. To ensure that the de-icing needs of individual flights are properly considered, the following additional procedures are typically applicable during de-icing operations:

- (a) A request for de-icing would normally be transmitted by the flight crew on the clearance delivery frequency.
- (b) If the flight crew determines, following clearance delivery, that de-icing is required, they would contact the AMU on the applicable radio frequency and request de-icing.

10.5.3 General and Business Aviation Operations — Air Operator Procedures

10.5.3.1 Prior Permission to Operate Required (Reservation)

Operators or the designated representatives of general and business aviation aircraft typically obtain prior permission to operate (reservation) from the applicable airport authority using A-CDM procedures up to 72 hours before the EOBT, or a minimum of 60 minutes before the EOBT of the planned operation. Some airports have special arrangements with GA/BA Tenant Carriers allowing them to book up to 30 days prior to the EOBT.

Permission or reservation can normally be obtained by contacting the airport authority.

10.5.3.2 Requirement to Provide the Target Off-Block Time (TOBT)

Similar to Commercial Air Transport Operations, General and Business Aviation flights must also have a TOBT. Operators can typically obtain their TOBT using the airport's A-CDM web portal.

10.5.3.3 Pre-Departure Sequencing — Target Start-Up Approval Time (TSAT) Generation

Based on the TOBT, a TSAT is generated by the A-CDM system for every flight. The TSAT is used to indicate the sequence in which aircraft can expect to receive start-up approval, ensuring an optimal flow of traffic to the assigned runways. An update to the TOBT will always result in the recalculation of the TSAT; however, this may not always result in a different position in the sequence for the flight concerned.

Any applicable constraints, like the CTOT resulting from TMIs, taxi times, and possible de-icing time are considered in the calculation of the TSAT, ensuring that such constraints are always met.

10.5.3.4 Access to the Target Start-Up Approval Time (TSAT)

The TSAT will be shown in the A-CDM web portal as follows:

- (a) 10 minutes before the TOBT; or
- (b) 20 minutes before the TOBT if the TSAT is later than the TOBT by 20 minutes or more (as may be the case due to TMIs).

10.5.3.5 The Importance of Updating the Target Off-Block Time (TOBT)

Operators or their designated representatives are obliged to update the TOBT if there is a difference of +/- 5 minutes compared to the initial or previously updated TOBT. Failing to update the TOBT will result in a TSAT that is no longer operationally correct. This, in turn, may cause the flight to be subject to unnecessary delay.

10.5.3.6 Target Off-Block Time (TOBT) Update Limitations

The TOBT may normally be updated as many times as necessary until 10 minutes prior to the TOBT. Thereafter, only two more updates are usually possible. Should a third update be necessary, the operator or its designated representative should contact the Manager of Operations, Airport Flow, for further instructions.

10.5.3.7 Method for Updating the Target Off-Block Time (TOBT)

The TOBT must be updated either by updating the flight plan EOBT or via the airports A-CDM web portal.

10.5.3.8 Target Off-Block Time (TOBT) and Target Start-Up Approval Time (TSAT) Delivery Channels

Several channels are provided for the delivery of the TOBT and TSAT to the flight crew, such as:

- (a) The A-CDM web portal;
- (b) Any specific means of communication that may exist between the operator or its designated representative and the flight crew; or
- (c) The AVGDS, where available.

10.5.3.9 Access to the Target Off-Block Time (TOBT)

The TOBT will be displayed for the flight crew on all channels as soon as it is set in the A-CDM system.

10.5.3.10 Access to the Target Start-Up Approval Time (TSAT)

The TSAT will usually be displayed for the flight crew on all channels as follows:

- (a) 10 minutes before the TBOT; or
- (b) 20 minutes before the TOBT if the TSAT is later than the TOBT by 20 minutes or more (as may be the case due to TMIs).

10.5.3.11 Call Ready Procedure

The flight crew should expect to call the AMU Apron Coordinator at TOBT +/- 5 minutes to confirm that the flight is ready as defined for the TOBT; they must state their location on the airport. The Apron Coordinator will advise the TSAT and then instruct the flight crew to change to the appropriate radio frequency. If the flight crew fails to call within the specified time window, it will be assumed that the TOBT is no longer valid and the corresponding TSAT will be removed from the sequence. The operator or its designated representative will need to provide a new TOBT for a new TSAT to be generated. This may result in a substantial delay for the flight concerned.

10.5.3.12 Start-Up Procedures

The start-up procedure typically commences at TSAT +/- 5 minutes without a need for the flight crew to make an additional call.

If the start-up process does not commence within 2 minutes of the TSAT time that was issued, the flight crew must call the AMU on the appropriate radio frequency, explain the situation, and request guidance on how to proceed. If this call is omitted, it will be assumed that the TSAT is no longer valid and it will be removed from the sequence. The operator or its designated representative needs to provide a new TOBT via the A-CDM web portal or via the Manager of Operations, Airport Flow, for a new TSAT to be generated. This may result in a substantial delay for the flight concerned.

If the start-up process is interrupted for any reason or if the start-up process is expected to take longer than normal, the flight crew must call the AMU on the appropriate radio frequency, explain the situation, and request guidance on how to proceed.

Flight crew are reminded that the actual order of start-up approval depends on the operational decisions of the AMU. Hence, a difference may exist between the system-generated sequence and the sequence as established by the AMU. However, even after such manual intervention, the applicable constraints, like CTOT, would be met by the modified sequence.

10.5.3.13 Flight Crew Concerns About Meeting Constraints

All functions of the A-CDM system are designed to ensure that applicable constraints, most importantly those resulting from TMIs, are always fully met. For example, the TSAT is calculated to take all applicable constraints into account. If duly observed by the flight crew, the runway slot (CTOT) allocated to the flight would not be missed.

Nevertheless, if flight crew members estimate that a TSAT assigned to them and their applicable CTOT are not compatible, they should contact their operator or ground handler to resolve the issue via the Manager of Operations, Airport Flow.

10.5.3.14 De-icing Operations

The need for de-icing has a substantial impact on standard A-CDM procedures, especially the extended taxi times needed to account for the duration of the de-icing operation. To ensure that the de-icing needs of individual flights are properly considered, the following additional procedures are applicable during de-icing operations:

- (a) A request for de-icing would normally be transmitted by the flight crew on the airport clearance delivery frequency.
- (b) If members of the flight crew determine after clearance delivery that de-icing is required, they must contact the AMU and request de-icing.

10.6 CONTINGENCY OPERATIONS

If the Airport Collaborative Decision Making (A-CDM) system fails or becomes unreliable, the A-CDM procedures will be suspended. The suspension and eventual restarting of the procedures will be announced via the airport terminal information service (ATIS) broadcast and a NOTAM. During suspension of the A-CDM procedures, no target off-block time (TOBT) or target start-up approval time (TSAT) will be provided.