



Transport
Canada
Motor Vehicle
Safety

Transports
Canada
Sécurité des
véhicules
automobiles

TEST METHOD 213.4

Built-in Restraint Systems and Built-in Booster Seats

Revised:
Issued:

November 2012R
October 15, 1993

(Ce document est aussi disponible en français)

Table of Contents

1. Introduction	1
2. Definitions	1
3. Test Devices to be Used	1
4. Pre-Test Buckle Release Force Measurement	3
5. Dynamic Test	6
5.1 Test Description	6
5.2 Test Conditions	6
5.3 Test Setup.....	7
5.4 Positioning the ATD and Preparation of the Built-in restraint system or Built-in Booster Seat	10
5.5 Test Procedure	17
6. Post-Dynamic Test Buckle Release Test	17

Table of Figures

Figure 1 — Self-Adjusting Sling for the Buckle Release Test	4
Figure 2 — Release Force Application Device	5
Figure 3 — Release Force Application Position for Push-button Mechanism	5
Figure 4 — Test Platform Acceleration Graph	6
Figure 5 — Webbing Tension Pull Device	14
Figure 6 — Lap Shield	15
Figure 7 — HIII-10C Dummy Neck Angle Setting is SP-16 Degrees	16
Figure 8 — HIII-10C Dummy Lumbar Angle Setting is SP-12 Degrees	16

List of Referenced Documents

ASTM International D-1056-07, *Standard Specification for Flexible Cellular Materials—Sponge or Expanded Rubber*, published by ASTM International

SAE International Recommended Practice J211-1, *Instrumentation for Impact Test – Part 1 – Electronic Instrumentation* (July 2007)

SAE International Recommended Practice J826 – *Device for Use in Defining and Measuring Vehicle Seating Accommodation* (July 1995)

Subparts E, N, O, P, R, S, and T part 572, chapter V, title 49 of the *Code of Federal Regulations* of the United States (revised as of October 1, 2012)

Technical Standards Document No. 301, *Fuel System Integrity*

1. Introduction

Test Method 213.4 — Built-in Restraint Systems and Built-in Booster Seats (November 2012) is referred to in section 213.4 of Schedule IV to the [Motor Vehicle Safety Regulations](#).

2. Definitions

- (a) **Specific vehicle shell** means the actual vehicle model part into which the built-in restraint system or built-in booster seat is fabricated, including the complete surroundings of the built-in restraint system or built-in booster seat. If the built-in restraint system or built-in booster seat is manufactured in
- (i) a passenger vehicle, a multi-purpose passenger vehicle or a truck, and is part of
 - (A) any seat in the second row of designated seating positions, the complete surroundings include the back of the seat in front, the interior rear side door panels and trim, the specific seat, the floor pan, the B and C pillars, and the ceiling;
 - (B) a front passenger seat, the complete surroundings include the dashboard, the steering wheel column, and attached levers and knobs, the A pillars, any levers and knobs installed on the floor or on a console, the interior front side door panels and trim, the specific seat, the floor pan and the ceiling.
 - (ii) a bus, these surroundings include the specific seat, the restraining barrier or seat in front, and the seat behind.

(châssis de véhicule de type particulier)

- (b) **Specific vehicle** means the actual vehicle model into which the built-in restraint system or built-in booster seat is fabricated. *(véhicule de type particulier)*

3. Test Devices to be Used

3.1 General:

The test device used in testing a built-in restraint system or a built-in booster seat must be either a specific vehicle shell or a specific vehicle.

3.2 Anthropomorphic test devices

For the dynamic tests, select all anthropomorphic test devices (ATD) specified in paragraph (a) to (d), as required, for testing a built-in restraint system or select all ATD specified in paragraph (b) to (d), as required, for testing a built-in booster seat for use by persons whose mass and height are within the ranges indicated in the statement required by paragraph 213.4(19)(a) of the [Motor Vehicle Safety Regulations](#).

- (a) A built-in restraint system that is designed to be used by persons in a specified mass range that includes any persons having a mass greater than 10 kg but not greater than 18 kg, or by persons in a specified height range that includes any persons whose height is greater than 850 mm but not greater than 1100 mm, must be tested with:
 - (i) the CRABI 12-month-old infant ATD conforming to subpart R, part 572, chapter V, title 49 of the *Code of Federal Regulations* of the United States (revised as of October 1, 2012); and
 - (ii) the Hybrid III 3-year-old child ATD conforming to subpart P, part 572, chapter V, title 49 of the *Code of Federal Regulations* of the United States (revised as of October 1, 2012).
- (b) A built-in restraint system or built-in booster seat that is designed to be used by persons in a specified mass range that includes any persons having a mass greater than 18 kg but not greater than 22.7 kg, or by persons in a specified height range that includes any persons whose height is greater than 1100 mm but not greater than 1250 mm, must be tested with the Hybrid III 6-year-old child ATD conforming to subpart N, part 572, chapter V, title 49 of the *Code of Federal Regulations* of the United States (revised as of October 1, 2012).
- (c) A built-in restraint system or built-in booster seat that is designed to be used by persons in a specified mass range that includes any persons having a mass greater than 22.7 kg but not greater than 30 kg, or by persons in a specified height range that includes any persons whose height is greater than 1100 mm but not greater than 1250 mm, must be tested with:
 - (i) the Hybrid III 6-year-old child ATD conforming to subpart N, part 572, chapter V, title 49 of the *Code of Federal Regulations* of the United States (revised as of October 1, 2012); and
 - (ii) the Hybrid III 6-year-old weighted child ATD conforming to subpart S, part 572, chapter V, title 49 of the *Code of Federal Regulations* of the United States (revised as of October 1, 2012)
- (d) A built-in restraint system or built-in booster seat that is designed to be used either by persons in a specified mass range that includes any persons having a mass greater than 30 kg but not greater than 36.3 kg, or by persons in a specified height range that includes any persons whose height is greater than 1250 mm must be tested with the Hybrid III 10-year-old child ATD conforming to subpart T, part 572, chapter V, title

49 of the *Code of Federal Regulations* of the United States (revised as of October 1, 2012).

- (e) A built-in restraint system or built-in booster seat that is designed to be used either by persons in a specified mass range that includes any persons having a mass greater than 36.3 kg, must be tested with the Hybrid III 5th percentile adult female ATD conforming to subpart O, part 572, chapter V, title 49 of the *Code of Federal Regulations* of the United States (revised as of October 1, 2012), except that both lower legs must be removed at the knees and that both lower arms must be removed at the elbows.

3.2.1 The clothing of any ATD other than the shoes, must be machine washed in water that is at a temperature of at least 71°C but not more than 82°C and machine dried at a temperature of at least 49°C but not more than 60°C for 30 minutes.

3.2.2 The clothing of any ATD must consist of:

- (a) for the CRABI 12-month-old infant ATD, subpart R, a cotton-polyester-based tight fitting sweatshirt with long sleeves and ankle-length pants whose combined mass is not more than 0.25 kg;
- (b) For the Hybrid III 3-year-old child ATD, subpart P, clothing as specified in 49 CFR part 572 Subpart P, and children's size 8 canvas oxford style sneakers weighing not more than 0.26 kg each.
- (c) For the Hybrid III 6-year-old child ATD, subpart N, and the Hybrid III 6-year-old weighted child ATD, subpart S, clothing as specified in 49 CFR part 572 Subpart N, and size 13 sneakers weighing not more than 0.45 kg each.
- (d) For the Hybrid III 10-year-old child ATD, subpart T, clothing as specified in 49 CFR part 572 Subpart T, and youth size 3 sneakers weighing not more than 0.6 kg each.
- (e) For the Hybrid III 5th percentile adult female, subpart O, form-fitting cotton stretch garments with short sleeves and above-the-knee pants, and sneakers with rubber soles and cotton or nylon uppers of the appropriate size.

3.2.3 For the purposes of the dynamic tests, any ATD used must be conditioned at an ambient temperature of at least 20.6°C but not more than 22.2°C and at a relative humidity of at least 10 % but not more than 70 % for at least 4 hours immediately prior to the test.

4. Pre-Test Buckle Release Force Measurement

4.1 If the belts of the built-in restraint system are equipped with buckles, the release force of each buckle is to be measured in accordance with subsections 4.2 to 4.6 before commencing the dynamic tests, using the heaviest of the ATDs specified in subsection 3.2 of this test method, other than the Hybrid III 5th percentile adult female ATD, subpart O.

4.2 Install the ATD in the built-in restraint system in accordance with subsection 5.4;

4.3 Tie a self-adjusting sling to the wrists and ankles of the ATD, as illustrated in Figure 1;

4.4 Pull the sling horizontally in the manner illustrated in Figure 1 and parallel to the longitudinal centreline of either the specific vehicle shell or the specific vehicle with a force of 90 N for a built-in restraint system tested with the CRABI 12-month-old infant ATD, subpart R; 200 N for a built-in restraint system tested with the Hybrid III 3-year-old child ATD, subpart P; 270 N for a built-in restraint system tested with the Hybrid III 6-year-old child ATD, subpart N, 350 N for a built-in restraint system tested with the Hybrid III 6-year-old weighted child ATD, subpart S, or 437 N for a built-in restraint system tested with the Hybrid III 10-year-old weighted child ATD, subpart T;

4.5 Operate the buckle release mechanism in the following manner:

- (a) For push-button-actuated buckles, the release force shall be applied to the buckle by a conical surface as shown in Figure 2 and,
 - (i) for push-button-actuated mechanisms with a fixed edge (referred to in Figure 3 as “hinge button”), the release force shall be applied at the centreline of the button, 3 mm away from the movable edge directly opposite to the fixed edge, and in the direction that produces maximum releasing effect.
 - (ii) for push-button-actuated mechanisms with no fixed edge (referred to in Figure 3 as “floating button”), the release force shall be applied at the centre of the release mechanism in the direction that produces the maximum releasing effect.
- (b) For all other buckle release mechanisms, the force shall be applied on the centreline of the buckle lever or finger tab in the direction that produces the maximum releasing effect.

4.6 Measure the buckle release force.

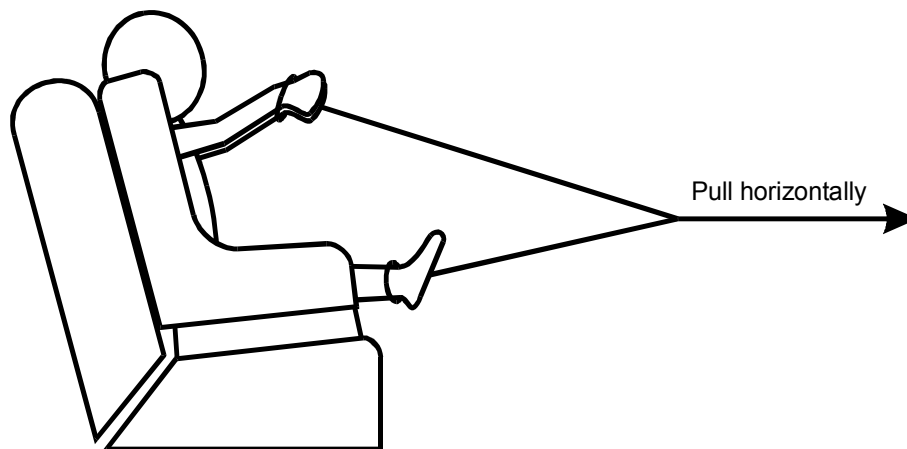

Figure 1 — Self-Adjusting Sling for the Buckle Release Test

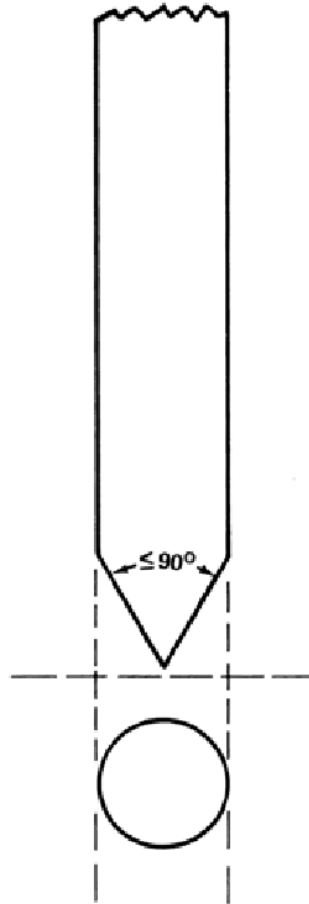

Figure 2 — Release Force Application Device

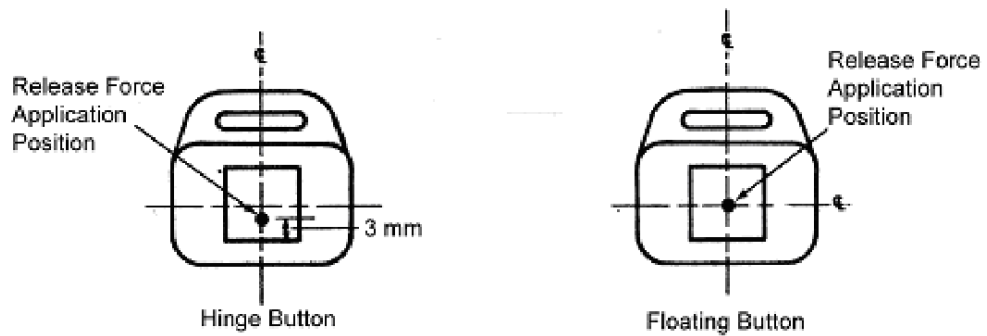

Figure 3 — Release Force Application Position for Push-button Mechanism

5. Dynamic Test

5.1 Test Description

The test must, at the option of the manufacturer, be either

- (a) a frontal barrier impact simulation using the specific vehicle shell mounted on the test platform, having an acceleration plot following every curve that meets the two following requirements:
 - (i) Be within the corridor shown in Figure 4; and
 - (ii) Represent a change of velocity of 48 km/h; or
- (b) a frontal barrier crash test of the entire specific vehicle, traveling longitudinally forward at a minimum velocity of 48 km/h impacting a fixed collision barrier that is at $90^\circ \pm 5^\circ$ to the line of travel of the vehicle.

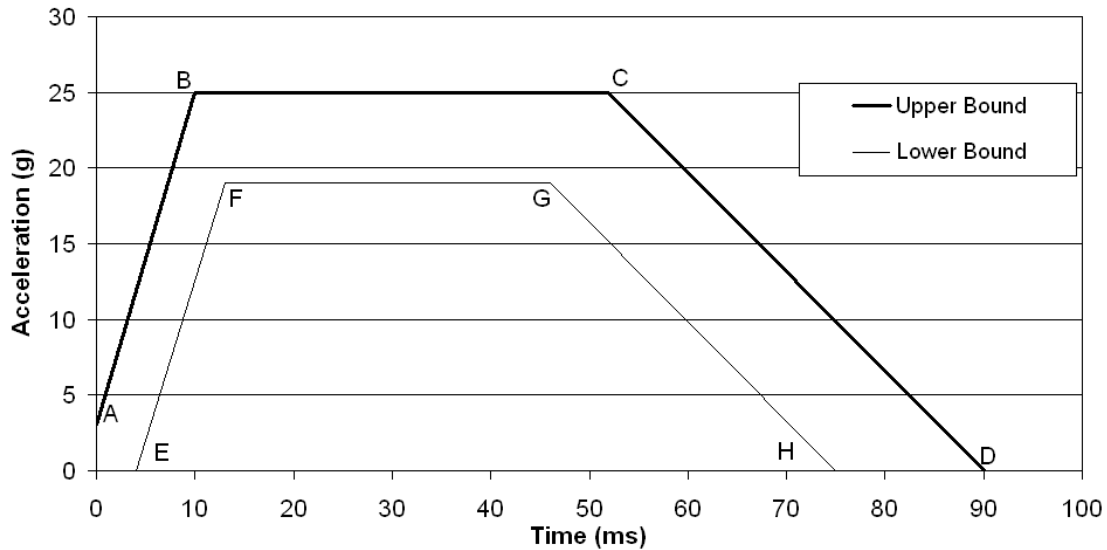

Upper Bound		
Point	Time	Acceleration
A	0	3
B	10	25
C	52	25
D	90	0
Lower Bound		
Point	Time	Acceleration
E	4	0
F	13	19
G	46	19
H	75	0

Figure 4 — Test Platform Acceleration Graph

5.2 Test Conditions

The dynamic test must be conducted at an ambient temperature of at least 20.6°C but not more than 22.2°C and at a relative humidity of at least 10 % but not more than 70 %.

5.3 Test Setup

5.3.1 When conducting the test with either the specific vehicle shell or the specific vehicle,

- (a) the built-in restraint system or built-in booster seats must be prepared in accordance with the instructions referred to in subsection 213.4(20) of the [*Motor Vehicle Safety Regulations*](#).
- (b) adjustable seats must be in the adjustment position midway between the forward-most and the rearmost positions, and if separately adjustable in a vertical direction, are at the lowest position. If an adjustment position does not exist midway between the forward-most and rearmost positions, the closest adjustment position to the rear of the midpoint must be used;
- (c) adjustable lumbar and side supports must be adjusted in the lowest position;
- (d) adjustable seat backs are placed in the manufacturer's nominal design riding position. If a nominal position is not specified, the vehicle seat back must be positioned, in the case of a designated seating position where a built-in restraint system or a built-in booster seat is tested, so that the accelerometer's platform in the head of the ATD used for testing, as initially positioned in the vehicle, is horizontal within 0.5°;
- (e) adjustable head restraints must be adjusted to their highest adjustment position if not otherwise specified in the manufacturer's instructions;
- (f) operable vehicle windows and vents must be placed in the fully closed position;
- (g) convertibles and open-body type vehicles must have the top, if any, in place in the closed passenger compartment configuration; and
- (h) doors must be fully closed and latched but not locked.

5.3.2 If the specific vehicle shell is selected for testing,

- (a) it must be mounted on a dynamic test platform so that the longitudinal centreline of the shell is parallel to the direction of travel of the test platform and any movement between the base of the shell and the platform is prevented; and
- (b) the test platform shall be instrumented with an accelerometer that is linked to a data processing system, and the accelerometer-sensitive axis shall be parallel to the direction of travel of the test platform. The data shall be filtered with a Class 60 filter, as specified in the SAE International Recommended Practice J211-1, *Instrumentation for Impact Test – Part 1 – Electronic Instrumentation* (July 2007); and
- (c) in the case of a school bus, two ATDs conforming to subpart O, part 572, chapter V, title 49 of the *Code of Federal Regulations* of the United States (revised as of October 1, 2012), must be positioned in the seat behind the specific seat to be tested; and
- (d) in the case of a bus, other than a school bus, two ATDs conforming to subpart E, part 572, chapter V, title 49 of the *Code of Federal Regulations* of the United States

(revised as of October 1, 2012), must be positioned in the seat behind the specific seat to be tested.

5.3.3 If the specific vehicle is selected for testing, the vehicle must be loaded to the following conditions:

- (a) in the case of a passenger car,
 - (i) it must be loaded to its unloaded vehicle mass;
 - (ii) it must be loaded with a cargo mass, secured in the luggage area, equal to:
[the vehicle capacity mass displayed on the vehicle placard] – [68 kg * the number of designated seating positions]
 - (iii) at the vehicle manufacturer's option, an ATD conforming to subpart B or subpart E, part 572, chapter V, title 49 of the *Code of Federal Regulations* of the United States (revised as of October 1, 2012), may be installed at the applicable front outboard seating positions.
 - (iv) the appropriate ATDs used to test the built-in restraint systems and built-in booster seats, in accordance with subsection 3.2, must be installed in accordance with section 5.
- (b) in the case of a multi-purpose passenger vehicle or truck,
 - (i) it must be loaded to its unloaded vehicle mass;
 - (ii) at the vehicle manufacturer's option, an ATD conforming to subpart B or subpart E, part 572, chapter V, title 49 of the *Code of Federal Regulations* of the United States (revised as of October 1, 2012), may be installed at the applicable front outboard seating positions.
 - (iii) the appropriate ATDs used to test the built-in restraint systems and built-in booster seats in accordance with subsection 3.2, must be installed in accordance with section 5.
 - (iv) it must be loaded with a mass, secured to the vehicle and distributed so that the mass on each axle, as measured at the tire-ground interface, is in proportion to its gross axle weight rating (GAWR), of 136 kg or a cargo mass, whichever is less, equal to:
[the vehicle capacity mass displayed on the vehicle placard of the vehicle] – [68 kg * the number of designated seating positions]
 - (v) if the mass on any axle, when the vehicle is loaded to the unloaded vehicle mass plus the mass of the ATDs, exceeds the axle's proportional share of the test mass, the remaining mass must be placed on the other axle(s).
- (c) in the case of a bus, other than a school bus,
 - (i) it must be loaded to its unloaded vehicle mass.

- (ii) at the vehicle manufacturer's option, an ATD conforming to subpart B or subpart E, part 572, chapter V, title 49 of the *Code of Federal Regulations* of the United States (revised as of October 1, 2012), may be installed at the driver's seating position.
 - (iii) the appropriate ATDs used to test the built-in restraint systems and built-in booster seats in accordance with subsection 3.2, must be installed in accordance with section 5.
 - (iv) it must be loaded with an unsecured mass of 68 kg at every designated seating position not referred to in (ii) or (iii).
 - (v) it must be loaded with a cargo mass, secured in the luggage area, equal to:
[the vehicle capacity mass displayed on the vehicle placard of the vehicle] – [68 kg * the number of designated seating positions]
- (d) in the case of a school bus,
- (i) it must be loaded to its unloaded vehicle mass.
 - (ii) at the vehicle manufacturer's option, an ATD conforming to subpart B or subpart E, part 572, chapter V, title 49 of the *Code of Federal Regulations* of the United States (revised as of October 1, 2012), may be installed at the driver's seating position.
 - (iii) the appropriate ATDs used to test the built-in restraint systems and built-in booster seats in accordance with subsection 3.2, must be installed in accordance with section 5.
 - (iv) it must be loaded with an unsecured mass of 54 kg at every designated seating position not referred to in (ii) or (iii).
- (e) if a built-in restraint system or built-in booster seat is supplied in the vehicle at one of the seating positions requiring the placement of a 50th percent male ATD, subpart B or subpart E, part 572, chapter V, title 49 of the *Code of Federal Regulations* of the United States (revised as of October 1, 2012) then this ATD must be substituted for the selected ATD use for testing the built-in restraint system or built-in booster seat, but only at that seating position. The loading specified above must be adjusted so that the final test mass remains as if the test had been performed with a 50th percent male ATD, subpart B or subpart E, part 572, chapter V, title 49 of the *Code of Federal Regulations* of the United States (revised as of October 1, 2012);
- (f) all instrumentation and data reduction must be in accordance with SAE International Recommended Practice J211-1, *Instrumentation for Impact Test – Part 1 – Electronic Instrumentation* (July 2007);
- (g) the tires must be inflated to the manufacturer's specification; and

- (h) the fuel tank must be filled to any level from 90 percent to 95 percent of capacity, and the rest of the fuel system must be filled to its normal operating capacity in accordance with *Technical Standards Document No. 301 — Fuel System Integrity*.

5.4 Positioning the ATD and Preparation of the Built-in restraint system or Built-in Booster Seat

5.4.1 Prepare each built-in restraint system and built-in booster seat in accordance with the instructions referred to in subsection 213.4(20) of the [Motor Vehicle Safety Regulations](#).

5.4.2 Place an ATD specified in subsection 3.2 in the built-in restraint system or built-in booster seat.

5.4.3 Any ATD placed in the built-in restraint system or built-in booster seat must be positioned in accordance with the manufacturer's instructions while conforming to the following:

- (a) In the case of a built-in restraint system:
- (i) Holding the torso upright until it contacts the seat back of the restraint system, seat the ATD in the restraint system so that the mid-sagittal plane of its head is vertical and parallel to the longitudinal centreline of the specific vehicle shell or the specific vehicle;
 - (ii) Lift the arms of the ATD as far as possible in the upward vertical direction. Extend the legs of the ATD as far as possible in the forward horizontal direction, with its feet perpendicular to the centreline of the lower legs;
 - (iii) Using a flat square surface with an area of 2 580 mm², apply a force of 178 N perpendicular to the back of the vehicle seat in the specific vehicle shell or the specific vehicle, first against the crotch of the ATD and then against the mid-sagittal plane of its thorax;
 - (iv) Position each movable surface in accordance with the instructions referred to in subsection 213.4(20) of the [Motor Vehicle Safety Regulations](#);
 - (v) If shoulder and pelvic belts are provided that directly restrain the ATD, they must be attached and adjusted by tightening the belts until a 9 N force applied simultaneously using a webbing tension pull device (as illustrated in Figure 5) to the webbing at the top of each shoulder and to the pelvic webbing 50 mm on either side of the mid-sagittal plane of the torso pulls the webbing a distance of 7 mm away from the ATD;
 - (vi) Rotate each limb of the ATD downward in a plane parallel to its mid-sagittal plane until the limb contacts a surface of the built-in restraint system system, the specific vehicle shell or the specific vehicle. Position the limbs so that they will not inhibit the movement of the torso or head during the test.
- (b) In the case of a built-in booster seat being tested with a Hybrid III 6-year-old weighted child ATD conforming to subpart S, part 572, chapter V, title 49 of the *Code of Federal Regulations* of the United States or the Hybrid III 5th percentile adult

female ATD conforming to subpart O, part 572, chapter V, title 49 of the *Code of Federal Regulations* of the United States:

- (i) Holding the torso upright until it contacts the seat back of the built-in booster seat, seat the ATD in the built-in booster seat so that the mid-sagittal plane of its head is vertical and parallel to the longitudinal centreline of the specific vehicle shell or the specific vehicle;
 - (ii) Lift the arms of the ATD as far upward as possible. Extend the legs of the ATD as far forward horizontally as possible, with its feet perpendicular to the centreline of the lower legs;
 - (iii) Using a flat square surface with an area of 2 580 mm², apply a force of 178 N perpendicular to the back of the vehicle seat in the specific vehicle shell or the specific vehicle, first against the crotch of the ATD and then against the mid-sagittal plane of its thorax;
 - (iv) Position each movable surface in accordance with the instructions referred to in subsection 213.4(20) of the [*Motor Vehicle Safety Regulations*](#);
 - (v) The type 2 seat belt assembly used to restrain the ATD is tightened to a tension of,
 - (A) for the upper torso restraint, not less than 9 N and not more than 18 N.
 - (B) for the pelvic restraint, not less than 9 N and not more than 18 N.
 - (vi) Rotate each limb of the ATD downward in a plane parallel to its mid-sagittal plane until the limb contacts a surface of the built-in booster seat, the specific vehicle shell or the specific vehicle. Position the limbs so that they will not inhibit the movement of the torso or head during the test.
- (c) In the case of a built-in booster seat being tested with a Hybrid III 6-year-old child ATD conforming to subpart N, part 572, chapter V, title 49 of the *Code of Federal Regulations* of the United States or, a Hybrid III 10-year-old child ATD conforming to subpart T, part 572, chapter V, title 49 of the *Code of Federal Regulations* of the United States:
- (i) *Prepare the ATD.*
 - (A) When using the Hybrid III 10-year-old ATD, prepare the ATD according to the following:
 - (1) Set the ATD 's neck angle at the SP-16 setting (“SP” means standard procedure), see Figure 7.
 - (2) Set the ATD 's lumbar angle at the SP-12 setting, see Figure 8. This is done by aligning the notch on the lumbar adjustment bracket with the SP-12 notch on the lumbar attachment.
 - (3) Adjust the limb joints to 1–2 g while the torso is in the seated position.

- (4) Apply double-sided tape to the surface of a lap shield, which is a piece of translucent silicone rubber 3 mm \pm 0.5 mm thick (50A durometer) cut to the dimensions specified in Figure 6. Place the lap shield on the pelvis of the ATD. Align the top of the lap shield with the superior anterior edge of the pelvis skin. Attach the lap shield to the ATD.
 - (5) Apply double-sided tape to one side of a pelvis positioning pad, which is a 125 \times 95 \times 20 mm (\pm 2 mm tolerance in each of the three dimensions) piece of closed cell (Type 2 according to ASTM D-1056-07, *Standard Specification for Flexible Cellular Materials—Sponge or Expanded Rubber*, published by ASTM International) foam or rubber cut from material having the following specifications: compression resistance between 9 to 17 psi in a compression-deflection test specified in ASTM D-1056-07, *Standard Specification for Flexible Cellular Materials—Sponge or Expanded Rubber*, published by ASTM International, and a density of 7 to 12.5 lb/ft³. Center the long axis of the pad on the posterior of the pelvis with the top edge of the foam aligned with the superior edge of the pelvis skin. Attach the pelvis positioning pad to the ATD.
 - (6) Dress and prepare the ATD according to section 3 of this test method.
- (B) When using the Hybrid III 6-year-old ATD, prepare the ATD according to the following:
- (1) If necessary, adjust the limb joints to 1–2 g while the torso is in the seated position.
 - (2) Apply double-sided tape to the surface of a lap shield, which is a piece of translucent silicone rubber 3 mm thick \pm 0.5 mm thick (50A durometer) cut to the dimensions specified in Figure 6. Place the lap shield on the pelvis of the ATD. Align the top of the lap shield with the superior anterior edge of the pelvis skin. Attach the lap shield to the ATD.
 - (3) Dress and prepare the ATD according to section 3 of this test method.
- (ii) Position the ATD.
- (A) Place the ATD on the seat cushion of the built-in booster seat such that the plane of the posterior pelvis is parallel to the plane of the vehicle seat back, but not touching. Pick up and move the ATD rearward, maintaining the parallel planes, until the pelvis positioning pad, if used, or the pelvis or back of the ATD and the back of the belt-positioning seat or the back of the standard seat assembly, are in minimal contact.
 - (B) Straighten and align the arm segments horizontally, then rotate the arms upward at the shoulder as far as possible without contacting the built-in booster seat. Straighten and align the legs horizontally and extend the lower legs as far as possible in the forward horizontal direction, with the feet perpendicular to the centerline of the lower legs.

- (C) Using a flat square surface with an area of 2580 square millimeters, apply a force of 178 N (40 lb) first against the ATD crotch and then against the ATD thorax on the mid-sagittal plane of the ATD, perpendicular to the plane of the back of the vehicle seat.
 - (D) Rotate the arms of the ATD down so that they are perpendicular to the torso.
 - (E) Bend the knees until the back of the lower legs are in minimal contact with the built-in booster seat. Position the legs such that the outer edges of the knees are 180 ± 10 mm apart for the Hybrid III 6-year-old ATD and 220 ± 10 mm apart for the Hybrid III 10-year-old ATD. Position the feet such that the soles are perpendicular to the centerline of the lower legs.
- (iii) *Apply the belt.* The type 2 seat belt assembly used to restrain the ATD is tightened to a tension of:
- (A) for the upper torso restraint, not less than 9 N and not more than 18 N.
 - (B) for the pelvic restraint, not less than 9 N and not more than 18 N.
- (iv) ATD final positioning.
- (A) Check the leg, feet, thorax and head positions and make any necessary adjustments to achieve the positions described in subsection 5.4.3 (c)(ii)(E) of this test method. Position the legs, if necessary, so that the leg placement does not inhibit thorax movement in tests.
 - (B) Rotate each ATD arm downwards in the plane parallel to the ATD 's mid-sagittal plane until the arm contacts a surface of the child restraint system or the standard seat assembly, in the case of an add-on system, or the specific vehicle shell or specific vehicle, in the case of a built-in system, as appropriate. Position the arms, if necessary, so that the arm placement does not inhibit torso or head movement in tests.

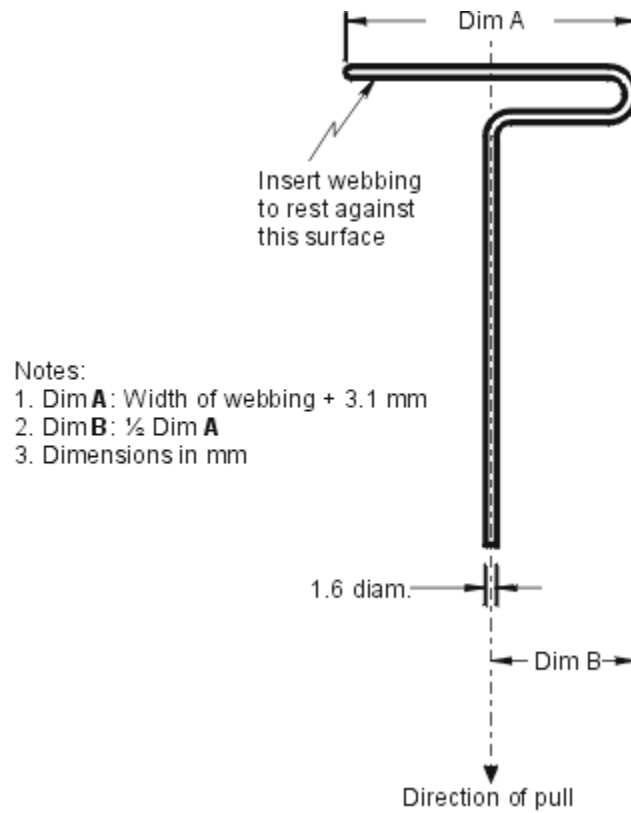

Figure 5 — Webbing Tension Pull Device

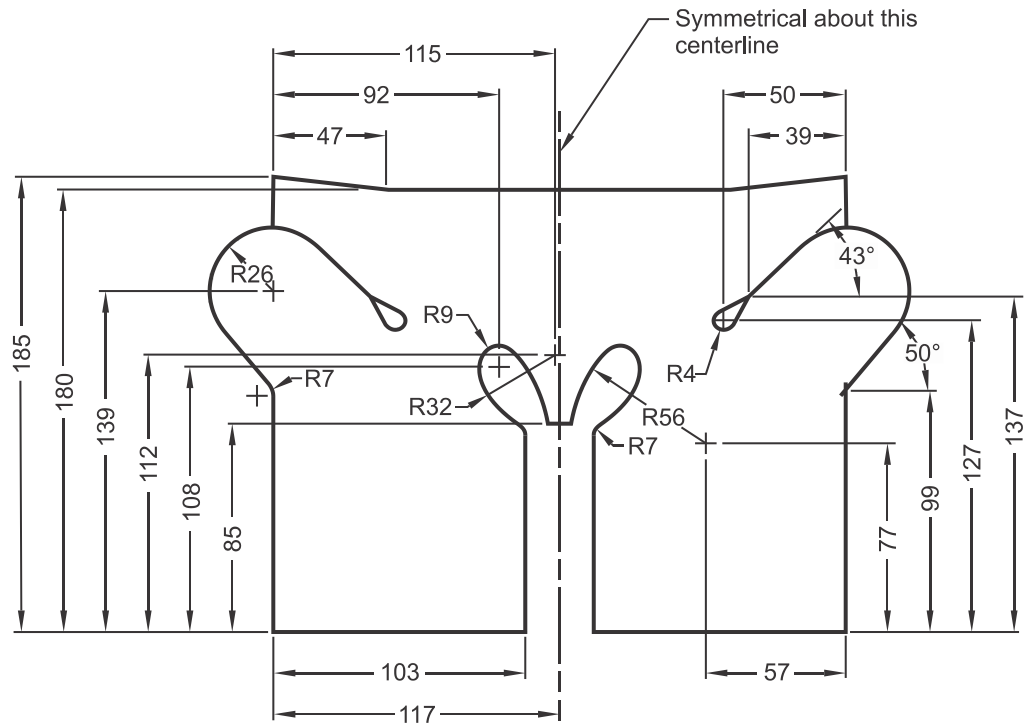

Figure 6 — Lap Shield

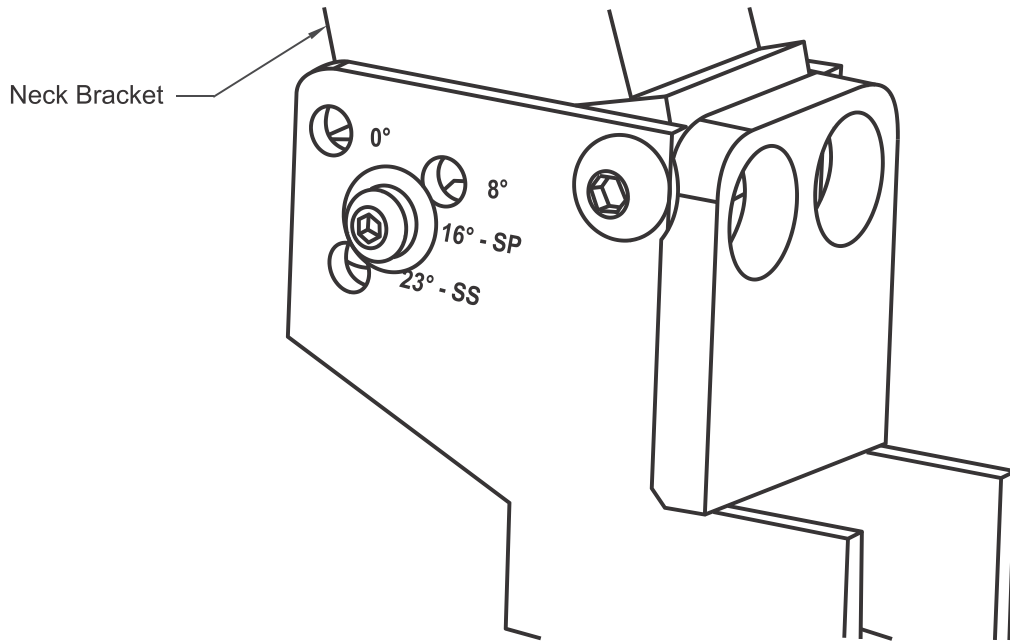

Figure 7 — HIII-10C Dummy Neck Angle Setting is SP-16 Degrees

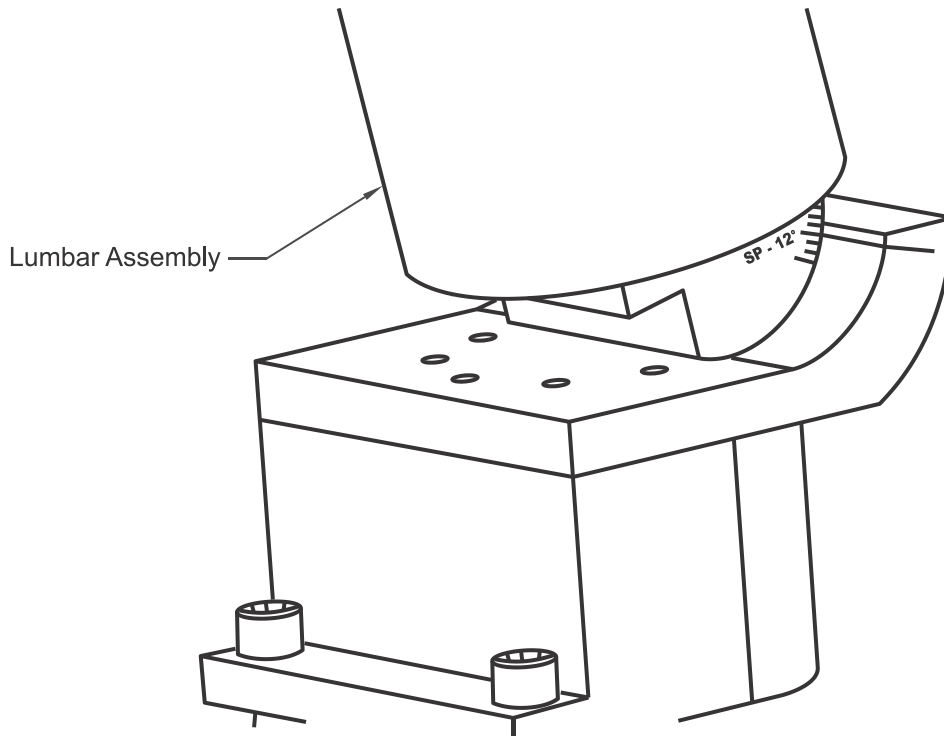

Figure 8 — HIII-10C Dummy Lumbar Angle Setting is SP-12 Degrees

5.5 Test Procedure

Perform the dynamic test in accordance with the procedure described in section 5.

6. Post-Dynamic Test Buckle Release Test

The buckle release test, as described in subsection 4.3 to 4.6, must be repeated after the dynamic test using the heaviest of the ATDs specified in subsection 3.2 of this test method for use in testing that built-in restraint system, except the Hybrid III 5th percentile adult female, subpart O.