



Transport  
Canada  
Motor Vehicle  
Safety

Transports  
Canada  
Sécurité des  
véhicules  
automobiles

## TECHNICAL STANDARDS DOCUMENT No. 305, Revision 4R

# Electrolyte Spillage and Electrical Shock Protection

The text of this document is based on Federal Motor Vehicle Safety Standard No. 305, Electric-powered vehicles: electrolyte spillage and electrical shock protection as published in the U.S.

*Code of Federal Regulations*, Title 49, Part 571, revised as of October 1, 2015 as well as the Notice of proposed rulemaking published in the *Federal Register* on March 10, 2016 (Vol. 81, No. 47, p. 12647).

**Publication Date:**

**December 22, 2016**

**Effective Date:**

**December 22, 2016**

**Mandatory Compliance Date:**

**December 22, 2018**

*(Ce document est aussi disponible en français)*

## Introduction

As defined by section 12 of the *Motor Vehicle Safety Act*, a Technical Standards Document (TSD) is a document that reproduces an enactment of a foreign government (e.g. a Federal Motor Vehicle Safety Standard issued by the U.S. National Highway Traffic Safety Administration). According to the Act, the [\*Motor Vehicle Tire Safety Regulations\*](#) may alter or override some provisions contained in a TSD or specify additional requirements; consequently, it is advisable to read a TSD in conjunction with the Act and the *Motor Vehicle Tire Safety Regulations*. As a guide, where the corresponding Regulation contains additional requirements, footnotes indicate the amending subsection number.

TSDs are revised from time to time in order to incorporate amendments made to the reference document, at which time a Notice of Revision is published in the *Canada Gazette*, Part I. All TSDs are assigned a revision number, with “Revision 0” designating the original version.

## Identification of Changes

In order to facilitate the incorporation of a TSD, certain non-technical changes may be made to the foreign enactment. These may include the deletion of words, phrases, figures, or sections that do not apply under the Act or Regulations, the conversion of imperial to metric units, the deletion of superseded dates, and minor changes of an editorial nature. Additions are underlined, and provisions that do not apply are ~~stroked through~~. Where an entire section has been deleted, it is replaced by: “[CONTENT DELETED]”. Changes are also made where there is a reporting requirement or reference in the foreign enactment that does not apply in Canada. For example, the name and address of the United States Department of Transportation are replaced by those of the Department of Transport.

## Effective Date and Mandatory Compliance Date

The effective date of a TSD is the date of publication of its incorporating regulation or of the notice of revision in the *Canada Gazette*, and the date as of which voluntary compliance is permitted. The mandatory compliance date is the date upon which compliance with the requirements of the TSD is obligatory. If the effective date and mandatory compliance date are different, manufacturers may follow the requirements that were in force before the effective date, or those of this TSD, until the mandatory compliance date.

In the case of an initial TSD, or when a TSD is revised and incorporated by reference by an amendment to the Regulations, the mandatory compliance date is as specified in the Regulations, and it may be the same as the effective date. When a TSD is revised with no corresponding changes to the incorporating Regulations, the mandatory compliance date is six months after the effective date.

## Official Version of Technical Standards Documents

The PDF version is a replica of the TSD as published by the Department and is to be used for the purposes of legal interpretation and application.

## Table of Contents

<b>Introduction</b> .....	<b>i</b>
<b>S1. Scope</b> .....	<b>1</b>
<b>S2. Purpose</b> .....	<b>1</b>
<b>S3. Application</b> .....	<b>1</b>
<b>S4. Definitions</b> .....	<b>1</b>
<b>S5. General requirements</b> .....	<b>3</b>
S5.1 Electrolyte spillage from propulsion batteries.....	3
S5.2 Electric energy storage/conversion device retention .....	4
S5.3 Electrical safety .....	4
S5.4 Electrical isolation monitoring .....	5
<b>S6. Test requirements</b> .....	<b>7</b>
S6.1 Frontal barrier crash.....	7
S6.2 Rear moving barrier impact.....	7
S6.3 Side moving deformable barrier impact .....	7
S6.4 Post-impact test static rollover.....	8
<b>S7. Test conditions</b> .....	<b>8</b>
S7.1 Electric energy storage device state-of-charge .....	8
S7.2 Vehicle conditions .....	8
S7.3 Static rollover test conditions .....	9
S7.4 Rear moving barrier impact test conditions.....	9
S7.5 Side moving deformable barrier impact test conditions.....	9
S7.6 Electrical isolation test procedure.....	9
S7.7 Voltage measurement. ....	10
<b>S8 Test procedure for on-board electrical isolation monitoring system</b> .....	<b>11</b>

## List of Figures

<b>Figure 1 — S7.6.3 and S7.7 Voltage Measurements of the High Voltage Source .....</b>	<b>13</b>
<b>Figure 2 — S7.6.4 Measurement for V1 Voltage between the Negative Side of the High Voltage Source and the Electrical Chassis .....</b>	<b>14</b>
<b>Figure 3 — S7.6.5 Measurement for V2 Voltage between the Positive Side of the High Voltage Source and the Electrical Chassis.....</b>	<b>15</b>
<b>Figure 4 — S7.6.6 Measurement for V1' Voltage across Resistor between Negative Side of the High Voltage Source and Electrical Chassis .....</b>	<b>16</b>
<b>Figure 5 — S7.6.7 Measurement for V2' Voltage across Resistor between Positive Side of High Voltage Source and Electrical Chassis.....</b>	<b>17</b>

## S1. Scope

This Technical Standards Document (TSD) standard specifies requirements for limitation of electrolyte spillage and retention of electric energy storage/conversion devices during and after a crash, and protection from harmful electric shock during and after a crash and during normal vehicle operation.

## S2. Purpose

The purpose of this TSD ~~standard~~ is to reduce deaths and injuries during and after a crash that occur because of electrolyte spillage from electric energy storage devices, intrusion of electric energy storage/conversion devices into the occupant compartment, and electrical shock, and to reduce deaths and injuries during normal vehicle operation that occur because of electric shock.

## S3. Application

[CONTENT DELETED] For applicability, please see Schedule III and subsection 305(1) of Schedule IV to the [Motor Vehicle Safety Regulations](#).

## S4. Definitions

**Automatic disconnect** means a device that when triggered, conductively separates a high voltage source from the electric power train or the rest of the electric power train. (*Dispositif de débranchement automatique*)

**Charge connector** is a conductive device that, by insertion into a vehicle charge inlet, establishes an electrical connection of the vehicle to the external electric power supply for the purpose of transferring energy and exchanging information. (*Connecteur de charge*)

**Direct contact** is the contact of persons with high voltage live parts. (*Contact direct*)

**Electric energy storage device** means a high voltage source that stores energy for vehicle propulsion. This includes, but is not limited to, a high voltage battery or battery pack, rechargeable energy storage device, and capacitor module. (*Dispositif d'accumulation d'énergie électrique*)

**Electric energy storage/conversion device** means a high voltage source that stores or converts energy for vehicle propulsion. This includes, but is not limited to, a high voltage battery or battery pack, fuel cell stack, rechargeable energy storage device, and capacitor module. (*Dispositif d'accumulation/de conversion d'énergie électrique*)

**Electric energy storage/conversion system** means an assembly of electrical components that stores or converts electrical energy for vehicle propulsion. This includes, but is not limited to, high voltage batteries or battery packs, fuel cell stacks, rechargeable energy storage systems, capacitor modules, inverters, interconnects, and venting systems. (*Système d'accumulation/de conversion d'énergie électrique*)

**Electric power train** means an assembly of electrically connected components which includes, but is not limited to, electric energy storage/conversion systems and propulsion systems. (*Groupe motopropulseur électrique*)

**Electrical chassis** means conductive parts of the vehicle whose electrical potential is taken as reference and which are: (1) conductively linked together, and (2) not high voltage sources during normal vehicle operation. (*Châssis électrique*)

**Electrical isolation** of a high voltage source in the vehicle means the electrical resistance between the high voltage source and any of the vehicle's electrical chassis divided by the working voltage of the high voltage source. (*Isolation électrique*)

**Electrical protection barrier** is the part providing protection against direct contact with live parts from any direction of access. (*Barrière de protection contre les décharges électriques*)

**Exposed conductive part** is the conductive part that can be touched under the provisions of the IPXXB protection degree and becomes electrically energized under isolation failure conditions. This includes parts under a cover that can be removed without using tools. (*Pièce conductrice exposée*)

**External electric power supply** is a power supply external to the vehicle that provides electric power to charge the propulsion battery in the vehicle. (*Source d'alimentation électrique externe*)

**Fuel cell system** is a system containing the fuel cell stack(s), air processing system, fuel flow control system, exhaust system, thermal management system, and water management system. (*Système de pile à combustible*)

**High voltage source** means any electric component contained in the electric power train or conductively connected to the electric power train that has a working voltage greater than 30 VAC or 60 VDC. (*Source à haute tension*)

**Indirect contact** is the contact of persons with exposed conductive parts. (*Contact indirect*)

**Live part** is a conductive part of the vehicle that is electrically energized under normal vehicle operation. (*Pièce sous tension*)

**Luggage compartment** is the space in the vehicle for luggage accommodation, separated from the passenger compartment by the front or rear bulkhead and bounded by a roof, hood, floor, and side walls, as well as by the electrical barrier and enclosure provided for protecting the power train from direct contact with live parts. (*Compartment à bagages*)

**Passenger compartment** is the space for occupant accommodation that is bounded by the roof, floor, side walls, doors, outside glazing, front bulkhead and rear bulkhead or rear gate, as well as electrical barriers and enclosures provided for protecting the occupants from direct contact with live parts. (*Habitacle*)

**Possible active driving mode** is the vehicle mode when application of pressure to the accelerator pedal (or activation of an equivalent control) or release of the brake system causes the electric power train to move the vehicle. (*Mode de conduite active possible*)

**Propulsion system** means an assembly of electric or electro-mechanical components or circuits that propel the vehicle using the energy that is supplied by a high voltage source. This includes, but is not limited to, electric motors, inverters/converters, and electronic controllers. (*Système de propulsion*)

**Protection degree IPXXB** is protection from contact with high voltage live parts. It is tested by probing electrical protection barriers or enclosures with the jointed test finger probe, IPXXB, in Figure 7b. (*Degré de protection IPXXB*)

**Protection degree IPXXD** is protection from contact with high voltage live parts. It is tested by probing electrical protection barriers or enclosures with the test wire probe, IPXXD, in Figure 7a. (*Degré de protection IPXXD*)

**Service disconnect** is the device for deactivation of an electrical circuit when conducting checks and services of the vehicle electrical propulsion system. (*Commande de mise hors tension aux fins d'entretien*)

**VAC** means volts of alternating current (AC) expressed using the root mean square value. (*VCA*)

**VDC** means volts of direct current (DC). (*VCC*)

**Vehicle charge inlet** is the device on the electric vehicle into which the charge connector is inserted for the purpose of transferring energy and exchanging information from an external electric power supply. (*Prise de charge du véhicule*)

**Working voltage** means the highest root mean square voltage of the voltage source, which may occur across its terminals or between its terminals and any conductive parts in open circuit conditions or under normal operating conditions. (*Tension de fonctionnement*)

## S5. General requirements

Each vehicle to which this ~~TSD standard~~ applies, must meet the requirements in S5.1, S5.2, and S5.3 when tested according to S6 under the conditions of S7.

### S5.1 Electrolyte spillage from propulsion batteries<sup>1</sup>

Not more than 5.0 liters of electrolyte from propulsion batteries shall spill outside the passenger compartment, and no visible trace of electrolyte shall spill into the passenger compartment. Spillage is measured from the time the vehicle ceases motion after a barrier impact test until 30 minutes thereafter, and throughout any static rollover after a barrier impact test.

---

<sup>1</sup> Please see subsection 305(5) of Schedule IV to the [Motor Vehicle Safety Regulations](#) (MVSR) for an additional requirement.

## S5.2 Electric energy storage/conversion device retention<sup>2</sup>

During and after each test specified in S6 of this TSD standard:

- (a) Electric energy storage/conversion devices shall remain attached to the vehicle by at least one component anchorage, bracket, or any structure that transfers loads from the device to the vehicle structure, and
- (b) Electric energy storage/conversion devices located outside the occupant compartment shall not enter the occupant compartment.

## S5.3 Electrical safety<sup>3</sup>

After each test specified in S6 of this TSD standard, each high voltage source in a vehicle must meet the electrical isolation requirements of paragraph S5.3(a) ~~of this section~~, the voltage level requirements of paragraph S5.3(b) ~~of this section~~, or the physical barrier protection requirements of paragraph S5.3(c) ~~of this section~~.

- (a) The electrical isolation of the high voltage source, determined in accordance with the procedure specified in S7.6 ~~of this section~~, must be greater than or equal to one of the following:
  - (1) 500 ohms/volt for an AC high voltage source; or
  - (2) 100 ohms/volt for an AC high voltage source if it is conductively connected to a DC high voltage source, but only if the AC high voltage source meets the physical barrier protection requirements specified in paragraph S5.3(c) ~~of this section~~; or
  - (3) 100 ohms/volt for a DC high voltage source.
- (b) The voltages V1, V2, and Vb of the high voltage source, measured according to the procedure specified in S7.7 ~~of this section~~, must be less than or equal to 30 VAC for AC components or 60 VDC for DC components.
- (c) Protection against electric shock by direct and indirect contact (physical barrier protection) shall be demonstrated by meeting the following three conditions:
  - (1) The high voltage source (AC or DC) meets the protection degree IPXXB when tested under the procedure specified in S9.1 ~~of this section~~ using the IPXXB test probe shown in Figures 7a and 7b ~~to this section~~;
  - (2) The resistance between exposed conductive parts of the electrical protection barriers and the electrical chassis is less than 0.1 ohms when

---

<sup>2</sup> Please see subsection 305(5) of Schedule IV to the [Motor Vehicle Safety Regulations](#) (MVSR) for an additional requirement.

<sup>3</sup> Please see subsection 305(5) of Schedule IV to the [Motor Vehicle Safety Regulations](#) (MVSR) for an additional requirement.



- tested under the procedures specified in S9.2 ~~of this section~~. In addition, the resistance between any two simultaneously reachable exposed conductive parts of the electrical protection barriers that are less than 2.5 meters from each other is less than 0.2 ohms when tested under the procedures specified in S9.2 ~~of this section~~; and
- (3) The voltages between the electrical protection barrier enclosing the high voltage source and other exposed conductive parts are less than or equal to 30 VAC or 60 VDC as measured in accordance with S9.3 ~~of this section~~.

## S5.4 Electrical safety during normal vehicle operation

### S5.4.1 Protection against direct contact.

S5.4.1.1 Marking. The symbol shown in Figure 6 ~~to this section~~ shall be visible on or near electric energy storage/conversion devices. The symbol in Figure 6 ~~to this section~~ shall also be visible on electrical protection barriers which, when removed, expose live parts of high voltage sources. The symbol shall be yellow and the bordering and the arrow shall be black.

S5.4.1.1.1 The marking is not required for electrical protection barriers that cannot be physically accessed, opened, or removed without the use of tools.

S5.4.1.2 *High voltage cables*. Cables for high voltage sources which are not located within enclosures shall be identified by having an outer covering with the color orange.

S5.4.1.3 *Service disconnect*. For a service disconnect which can be opened, disassembled, or removed without tools, protection degree IPXXB shall be provided when tested under procedures specified in S9.1 ~~of this section~~ using the IPXXB test probe shown in Figures 7a and 7b ~~to this section~~.

### S5.4.1.4 Protection degree of high voltage sources and live parts.

- a. Protection degree IPXXD shall be provided for live parts and high voltage sources inside the passenger or luggage compartment when tested under procedures specified in S9.1 ~~of this section~~ using the IPXXD test probe shown in Figure 7a ~~to this section~~.
- b. Protection degree IPXXB shall be provided for live parts and high voltage sources in areas other than the passenger or luggage compartment when tested under procedures specified in S9.1 ~~of this section~~ using the IPXXB test probe shown in Figures 7a and 7b ~~to this section~~.

### S5.4.2 Protection against indirect contact.

S5.4.2.1 The resistance between all exposed conductive parts and the electrical chassis shall be less than 0.1 ohms when tested under the procedures specified in S9.2 ~~of this section~~.

S5.4.2.2 The resistance between any two simultaneously reachable exposed conductive parts of the electrical protection barriers that are less than 2.5 meters from each other shall not exceed 0.2 ohms when tested under the procedures specified in S9.2 ~~of this section~~.

### S5.4.3 Electrical isolation.

S5.4.3.1 *Electrical isolation of AC and DC high voltage sources.* The electrical isolation of a high voltage source, determined in accordance with the procedure specified in S7.6 of this section must be greater than or equal to one of the following:

- a. 500 ohms/volt for an AC high voltage source;
- b. 100 ohms/volt for an AC high voltage source if it is conductively connected to a DC high voltage source, but only if the AC high voltage source meets the requirements for protection against direct contact in S5.4.1.4 of this section and the protection from indirect contact in S5.4.2 of this section; or
- c. 100 ohms/volt for a DC high voltage source.

S5.4.3.2 *Exclusion of high voltage sources from electrical isolation requirements.* A high voltage source that is conductively connected to an electric energy storage device which is conductively connected to the electrical chassis and has a working voltage less than or equal to 60 VDC, is not required to meet the electrical isolation requirements in S5.4.3.1 of this section during normal vehicle operating conditions if the voltage between the high voltage source and the electrical chassis is less than or equal to 30 VAC or 60 VDC.

S5.4.3.3 *Isolation resistance of high voltage sources for charging the electric energy storage device.* For motor vehicles with an electric energy storage device that can be charged through a conductive connection with the grounded external electric power supply, the isolation resistance between the electrical chassis and the vehicle charge inlet and each high voltage source conductively connected to the vehicle charge inlet during charging of the electric energy storage device shall be a minimum of one million ohms when the charge connector is disconnected. The isolation resistance is determined in accordance with the procedure specified in S7.6 of this section.

S5.4.4 *Electrical isolation monitoring.* Each DC high voltage sources of vehicles with a fuel cell system shall be monitored by an electrical isolation monitoring system that displays a warning for loss of isolation when tested according to S8 of this section. The system must monitor its own readiness and the warning display must be visible to the driver seated in the driver's designated seating position.

S5.4.5 *Electric shock protection during charging.* For motor vehicles with an electric energy storage device that can be charged through a conductive connection with a grounded external electric power supply, a device to enable conductive connection of the electrical chassis to the earth ground shall be provided. This device shall enable connection to the earth ground before exterior voltage is applied to the vehicle and retain the connection until after the exterior voltage is removed from the vehicle.

S5.4.6 Mitigating driver error.

S5.4.6.1 *Indicator of possible active driving mode at start up.* At least a momentary indication shall be given to the driver when the vehicle is in possible active driving mode. This requirement does not apply under conditions where an internal combustion engine provides directly or indirectly the vehicle's propulsion power upon start up.

S5.4.6.2 *Indicator of possible active driving mode when leaving the vehicle.* When leaving the vehicle, the driver shall be informed by an audible or visual signal if the vehicle is still in the possible active driving mode.

S5.4.6.3 *Prevent drive-away during charging.* If the on-board electric energy storage device can be externally charged, vehicle movement by its own propulsion system shall not be possible as long as the charge connector of the external electric power supply is physically connected to the vehicle charge inlet.

## S6. Test requirements

Each vehicle to which this TSD standard applies, under the conditions of S7, must be capable of meeting the requirements of any applicable single barrier crash/static rollover test sequence, without alteration of the vehicle during the test sequence. A particular vehicle need not meet further test requirements after having been subjected to a single barrier crash/static rollover test sequence.

### S6.1 Frontal barrier crash

The vehicle must meet the requirements of S5.1, S5.2, and S5.3 when it is traveling longitudinally forward at any speed, up to and including 48 km/h, and impacts a fixed collision barrier that is perpendicular to the line of travel of the vehicle, or at any angle up to 30 degrees in either direction from the perpendicular to the line of travel of the vehicle.

### S6.2 Rear moving barrier impact<sup>4, 5</sup>

The vehicle must meet the requirements of S5.1, S5.2, and S5.3, when it is impacted from the rear by a barrier that conforms to S7.3(b) of the U.S. Code of Federal Regulations (CFR), Title 49, Part 571, Standard No. 301 (hereinafter referred to as 49 CFR 571.301) of this chapter and that is moving at any speed up to and including 80 km/h (50 mph) with dummies in accordance with S6.2 of 49 CFR 571.301 of this chapter.

### S6.3 Side moving deformable barrier impact<sup>6</sup>

The vehicle must meet the requirements of S5.1, S5.2, and S5.3 when it is impacted from the side by a barrier that conforms to 49 CFR part 587 of this chapter that is moving at any speed up to and including 54 km/h, with the appropriate 49 CFR part 572 test dummies specified in 49 CFR 571.214 of this chapter.

---

<sup>4</sup> Please see subsection 305(2) of Schedule IV to the [Motor Vehicle Safety Regulations \(MVSR\)](#) for an additional requirement.

<sup>5</sup> Please see subsection 305(4) of Schedule IV to the [Motor Vehicle Safety Regulations \(MVSR\)](#) for an additional requirement.

<sup>6</sup> Please see subsection 305(5) of Schedule IV to the [Motor Vehicle Safety Regulations \(MVSR\)](#) for an additional requirement.

## **S6.4 Post-impact test static rollover**

The vehicle must meet the requirements of S5.1, S5.2, and S5.3, after being rotated on its longitudinal axis to each successive increment of 90 degrees after each impact test specified in S6.1, S6.2, and S6.3.

## **S7. Test conditions**

When the vehicle is tested according to S6, the requirements of S5.1 through S5.3 must be met under the conditions specified in S7.1 through S7.7. All measurements for calculating voltage(s) and electrical isolation are made after a minimum of 5 seconds after the vehicle comes to rest in tests specified in S6. Where a range is specified, the vehicle must be capable of meeting the requirements at all points within the range.

### **S7.1 Electric energy storage device state-of-charge**

The electric energy storage device shall be at the state-of-charge specified in either subparagraph (a), (b), or (c):

- (a) At the maximum state-of-charge in accordance with the vehicle manufacturer's recommended charging procedures, as stated in the vehicle owner's manual or on a label that is permanently affixed to the vehicle; or
- (b) If the manufacturer has made no recommendation for charging procedures in the owner's manual or on a label permanently affixed to the vehicle, at a state-of-charge of not less than 95 percent of the maximum capacity of the electric energy storage device; or
- (c) If the electric energy storage device(s) is/are rechargeable only by an energy source on the vehicle, at any state-of-charge within the normal operating voltage defined by the vehicle manufacturer.

### **S7.2 Vehicle conditions**

The switch or device that provides power from the electric energy storage/conversion system to the propulsion system is in the activated position or the ready-to-drive position.

**S7.2.1** The parking brake is disengaged and the transmission, if any, is in the neutral position. In a test conducted under S6.3, the parking brake is set.

**S7.2.2** Tires are inflated to the manufacturer's specifications.

### **S7.2.3 The vehicle, including test devices and instrumentation, is loaded as follows<sup>7</sup>:**

- (a) A passenger car is loaded to its unloaded vehicle ~~weight~~ mass plus its rated cargo and luggage capacity ~~weight~~ mass, secured in the luggage area, plus the necessary test dummies as specified in S6, restrained only by means that are installed in the vehicle for protection at its seating position.
- (b) A multipurpose passenger vehicle, truck, or bus with a GVWR of 4 536 kg or less is loaded to its unloaded vehicle ~~weight~~ mass plus the necessary dummies, as specified in S6, plus 136 kg or its rated cargo and luggage capacity ~~weight~~ mass, whichever is less. Each dummy is restrained only by means that are installed in the vehicle for protection at its seating position.

### **S7.3 Static rollover test conditions**

In addition to the conditions of S7.1 and S7.2, the conditions of S7.4 of Sec. 49 CFR 571.301 ~~of this chapter~~ apply to the conduct of static rollover tests specified in S6.4.

### **S7.4 Rear moving barrier impact test conditions<sup>8</sup>**

In addition to the conditions of S7.1 and S7.2, the conditions of S7.3(b) and S7.6 of 49 CFR 571.301 ~~of this chapter~~ apply to the conducting of the rear moving deformable barrier impact test specified in S6.2.

### **S7.5 Side moving deformable barrier impact test conditions<sup>9</sup>**

In addition to the conditions of S7.1 and S7.2, the conditions of S8.9, S8.10, and S8.11 of 49 CFR 571.214 ~~of this chapter~~ apply to the conduct of the side moving deformable barrier impact test specified in S6.3.

### **S7.6 Electrical isolation test procedure**

In addition to the conditions of S7.1 and S7.2, the conditions in S7.6.1 through S7.6.7 apply to the measuring of electrical isolation specified in S5.3(a).

---

<sup>7</sup> Please see subsection 305(3) of Schedule IV to the [Motor Vehicle Safety Regulations](#) (MVSR) for an additional requirement.

<sup>8</sup> Please see subsection 305(2) of Schedule IV to the [Motor Vehicle Safety Regulations](#) (MVSR) for an additional requirement.

<sup>9</sup> Please see subsection 305(2) of Schedule IV to the [Motor Vehicle Safety Regulations](#) (MVSR) for an additional requirement.

**S7.6.1** Prior to any barrier impact test, the energy storage/conversion system is connected to the vehicle's propulsion system, and the vehicle ignition is in the "on" (propulsion system energized) position. Bypass any devices or systems that do not allow the propulsion system to be energized at the time of impact when the vehicle ignition is on and the vehicle is in neutral. For a high voltage source that has an automatic disconnect that is physically contained within itself, the electrical isolation measurement after the test is made from the side of the automatic disconnect connected to the electric power train or to the rest of the electric power train if the high voltage source is a component contained in the power train. For a high voltage source that has an automatic disconnect that is not physically contained within itself, the electrical isolation measurement after the test is made from both the high voltage source side of the automatic disconnect and from the side of the automatic disconnect connected to the electric power train or to the rest of the electric power train if the high voltage source is a component contained in the power train.

**S7.6.2** The voltmeter used in this test has an internal resistance of at least 10 M $\Omega$ .

**S7.6.3** The voltage(s) is/are measured as shown in Figure 1 and the high voltage source voltage(s) ( $V_b$ ) is/are recorded. Before any vehicle impact test,  $V_b$  is equal to or greater than the nominal operating voltage as specified by the vehicle manufacturer.

**S7.6.4** The voltage  $V_1$  between the negative side of the high voltage source and the electrical chassis is measured as shown in Figure 2.

**S7.6.5** The voltage  $V_2$  between the positive side of the high voltage source and the electrical chassis is measured as shown in Figure 3.

**S7.6.6** If  $V_1$  is greater than or equal to  $V_2$ , insert a known resistance ( $R_o$ ) between the negative side of the high voltage source and the electrical chassis. With the  $R_o$  installed, measure the voltage ( $V_1'$ ) as shown in Figure 4 between the negative side of the high voltage source and the electrical chassis. Calculate the electrical isolation resistance ( $R_i$ ) according to the formula shown. Divide  $R_i$  (in ohms) by the working voltage of the high voltage source (in volts) to obtain the electrical isolation (in ohms/volt).

**S7.6.7** If  $V_2$  is greater than  $V_1$ , insert a known resistance ( $R_o$ ) between the positive side of the high voltage source and the electrical chassis. With the  $R_o$  installed, measure the voltage ( $V_2'$ ) as shown in Figure 5 between the positive side of the high voltage source and the electrical chassis. Calculate the electrical isolation resistance ( $R_i$ ) according to the formula shown. Divide  $R_i$  (in ohms) by the working voltage of the high voltage source (in volts) to obtain the electrical isolation (in ohms/volt).

## **S7.7 Voltage measurement.**

For the purpose of determining the voltage level of the high voltage source specified in S5.3(b), voltage is measured as shown in Figure 1. Voltage  $V_b$  is measured across the two terminals of the voltage source. Voltages  $V_1$  and  $V_2$  are measured between the source and the electrical chassis. For a high voltage source that has an automatic disconnect that is physically contained within itself, the voltage measurement after the test is made from the side of the automatic disconnect connected to the electric power train or to the rest of the electric power train if the high voltage source is a component contained in the power train.

For a high voltage source that has an automatic disconnect that is not physically contained within itself, the voltage measurement after the test is made from both the high voltage source side of the automatic disconnect and from the side of the automatic disconnect connected to the electric power train or to the rest of the electric power train if the high voltage source is a component contained in the power train.

## **S8 Test procedure for on-board electrical isolation monitoring system.**

Prior to any impact test, the requirements of S5.4 for the on-board electrical isolation monitoring system shall be tested using the following procedure.

- (1) The electric energy storage device is at the state-of-charge specified in S7.1.
- (2) The switch or device that provides power from the electric energy storage/conversion system to the propulsion system is in the activated position or the ready-to-drive position.
- (3) Determine the isolation resistance,  $R_i$ , of the high voltage source with the electrical isolation monitoring system using the procedure outlined in S7.6.2 through S7.6.7.
- (4) Insert a resistor with resistance  $R_o$  equal to or greater than  $1/(1/(95 \text{ times the working voltage of the high voltage source})-1/R_i)$  and less than  $1/(1/(100 \text{ times the working voltage of the high voltage source})-1/R_i)$  between the positive terminal of the high voltage source and the electrical chassis.
- (5) The electrical isolation monitoring system indicator shall display a warning visible to the driver seated in the driver's designated seating position.

## **S9 Test methods for physical barrier protection from electric shock due to direct and indirect contact with high voltage sources.**

### **S9.1 Test method to evaluate protection from direct contact with high voltage sources.**

- (a) Any parts surrounding the high voltage components are opened, disassembled, or removed without the use of tools.
- (b) The selected access probe is inserted into any gaps or openings of the electrical protection barrier with a test force of  $10 \text{ N} \pm 1 \text{ N}$  with the IPXXB probe or 1 to 2 N with the IPXXD probe. If partial or full penetration into the physical barrier occurs, the probe shall be placed as follows: Starting from the straight position, both joints of the test finger are rotated progressively through an angle of up to 90 degrees with respect to the axis of the adjoining section of the test finger and are placed in every possible position.
- (c) A low voltage supply (of not less than 40 V and not more than 50 V) in series with a suitable lamp may be connected between the access probe and any high

voltage live parts inside the physical barrier to indicate whether live parts were contacted.

- (d) A mirror or fiberscope may be used to inspect whether the access probe touches high voltage parts inside the physical barrier.

### **S9.2 Test method to evaluate protection against indirect contact with high voltage sources.**

- (a) Test method using a resistance tester.  
The resistance tester is connected to the measuring points (the electrical chassis and any exposed conductive part of the vehicle or any two exposed conductive parts that are less than 2.5 meters from each other), and the resistance is measured using a resistance tester that can measure current levels of at least 0.1 Amperes with a resolution of 0.01 ohms or less.
- (b) Test method using a DC power supply, voltmeter and ammeter.
  - (1) Connect the DC power supply, voltmeter and ammeter to the measuring points (the electrical chassis and any exposed conductive part or any two exposed conductive parts that are less than 2.5 meters from each other) as shown in Figure 8 ~~to this section~~.
  - (2) Adjust the voltage of the DC power supply so that the current flow becomes more than 0.2 Amperes.
  - (3) Measure the current I and the voltage V shown in Figure 8 ~~to this section~~.
  - (4) Calculate the resistance R according to the formula,  $R=V/I$ .

### **S9.3 Test method to determine voltage between electrical protection barrier and exposed conductive parts, including electrical chassis, of the vehicle.**

- (a) Connect the DC power supply and voltmeter to the measuring points (exposed conductive part of an electrical protection barrier and the electrical chassis or any other exposed conductive part of the vehicle).
- (b) Measure the voltage.
- (c) After completing the voltage measurements for all electrical protection barriers, the voltage differences between all exposed conductive parts of the protective barriers shall be calculated.



Figure 1 — S7.6.3 and S7.7 Voltage Measurements of the High Voltage Source

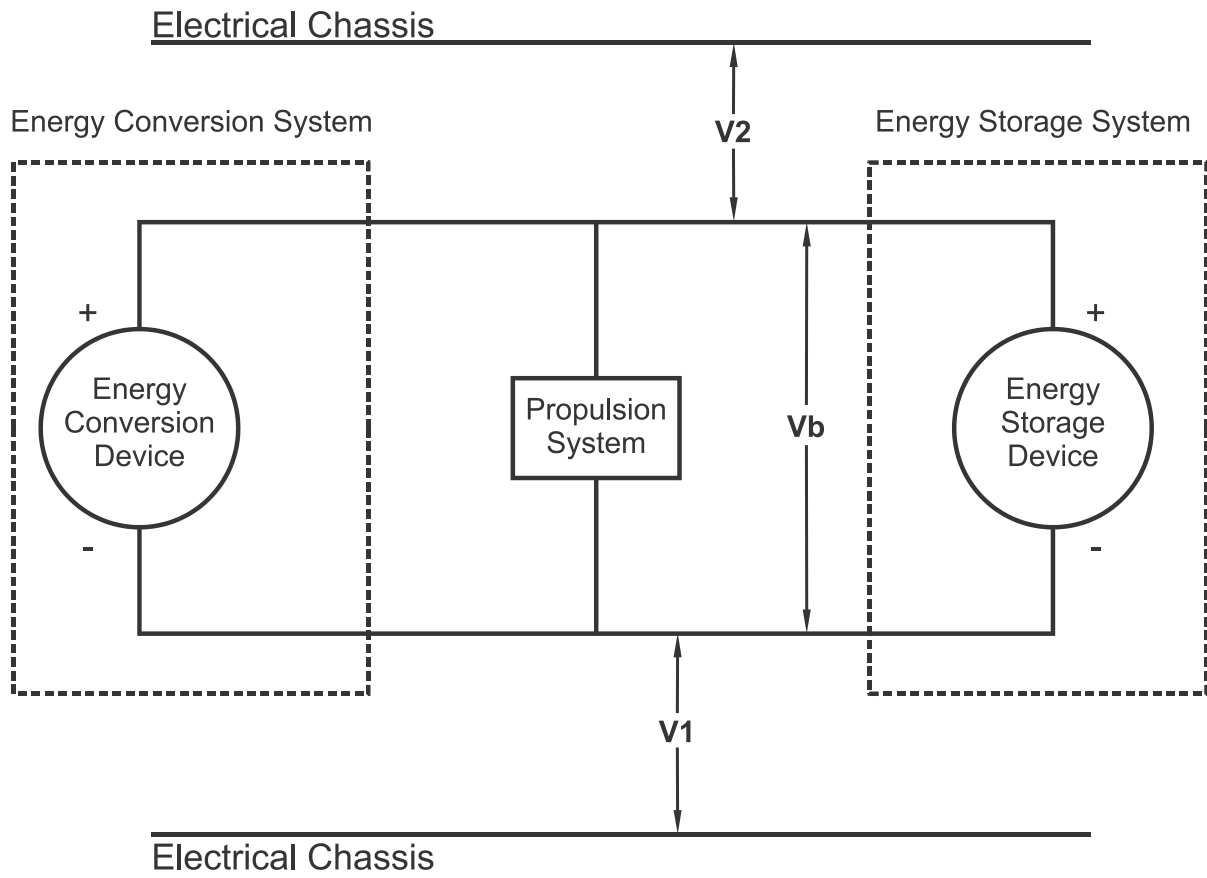

**Figure 2 — S7.6.4 Measurement for V1 Voltage between the Negative Side of the High Voltage Source and the Electrical Chassis**

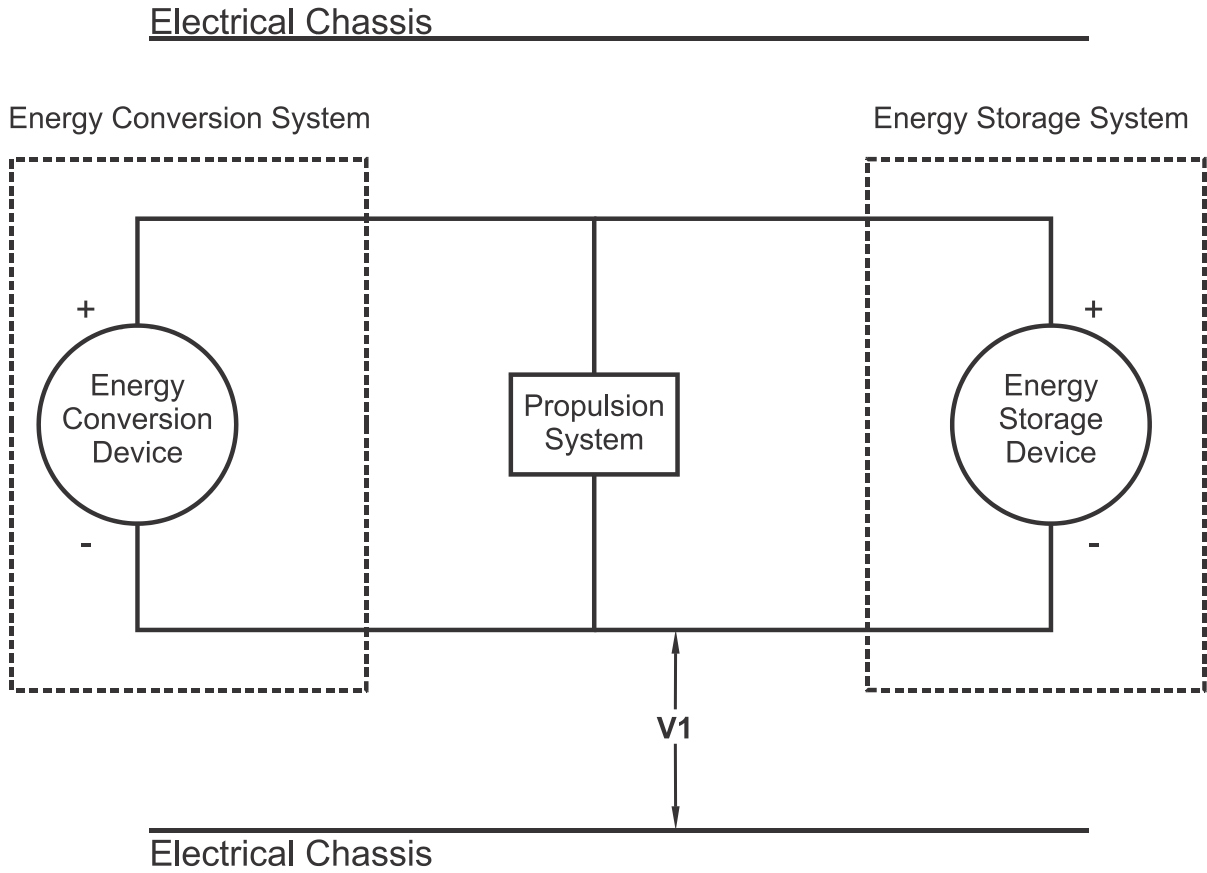
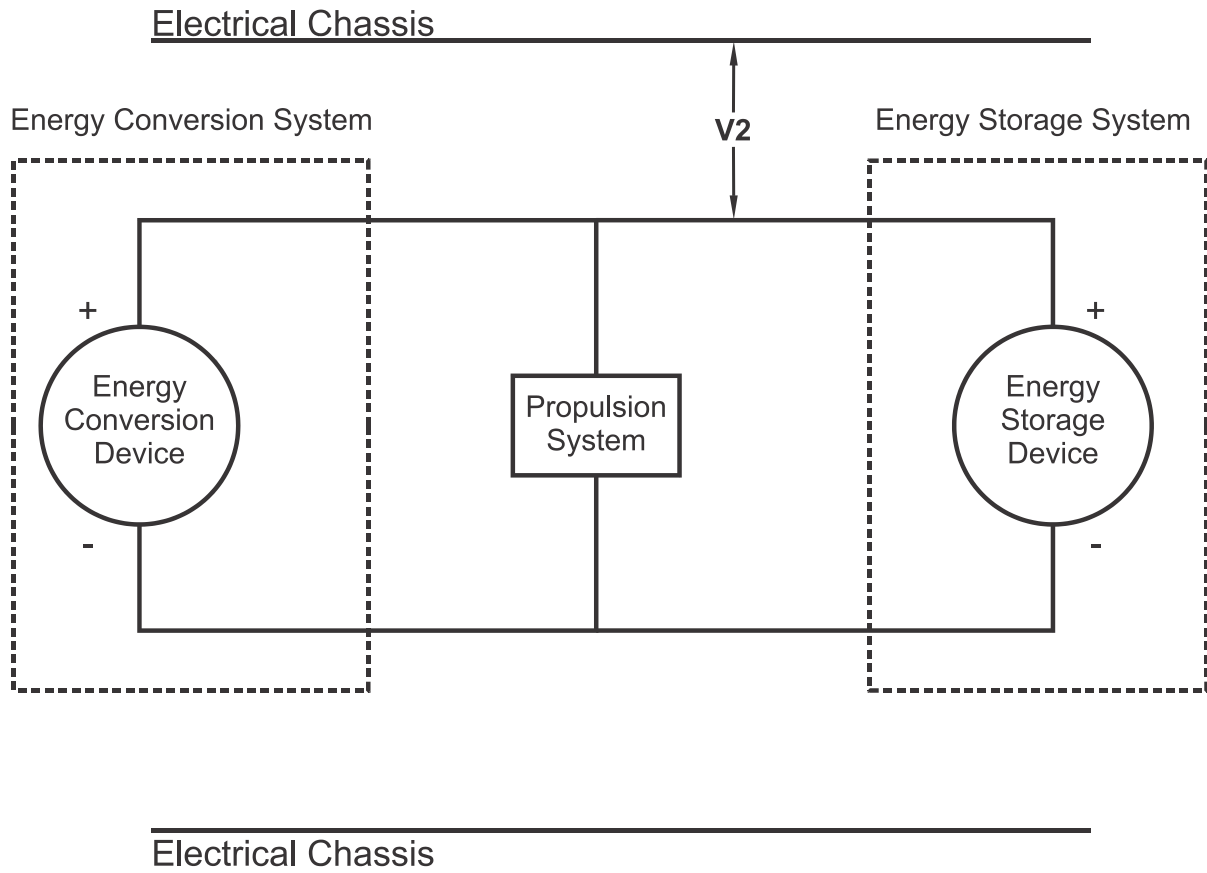
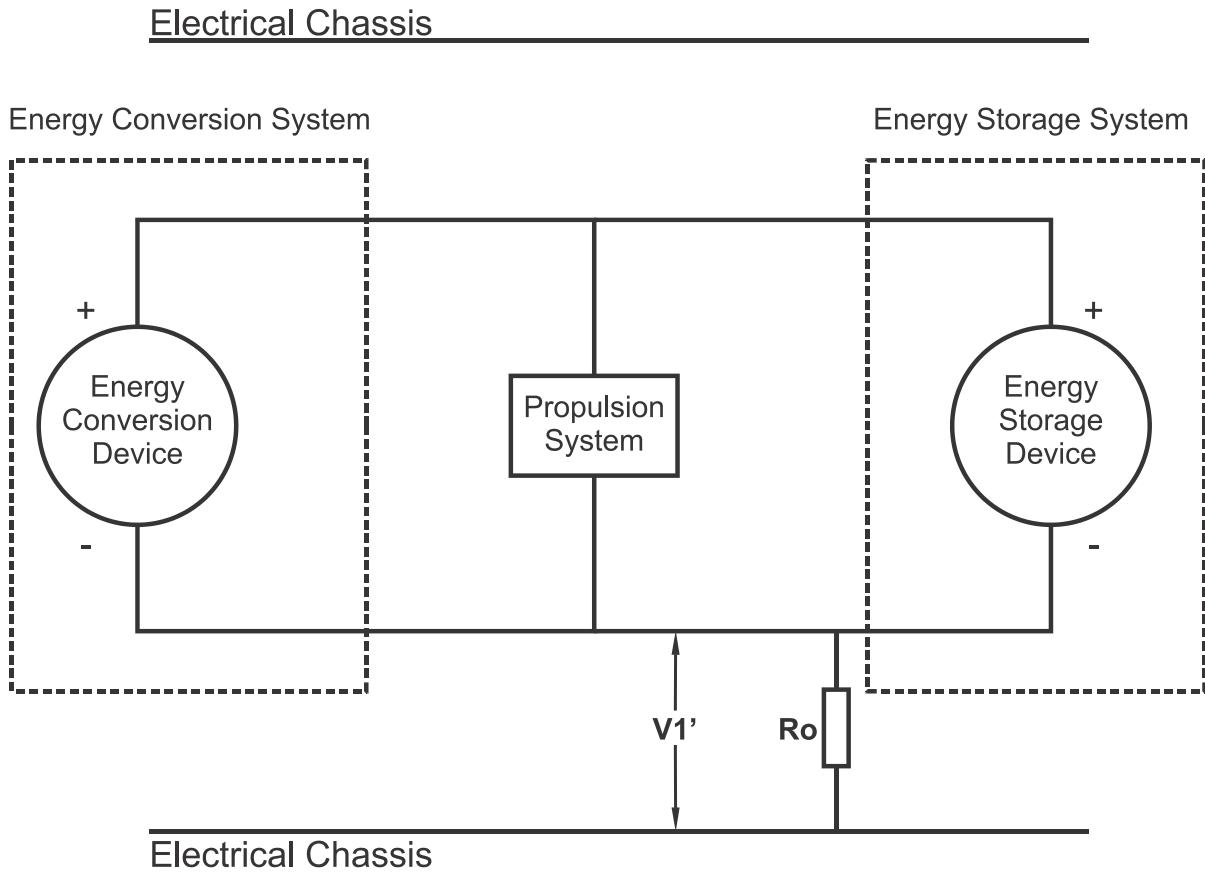

Figure 3 — S7.6.5 Measurement for V2 Voltage between the Positive Side of the High Voltage Source and the Electrical Chassis

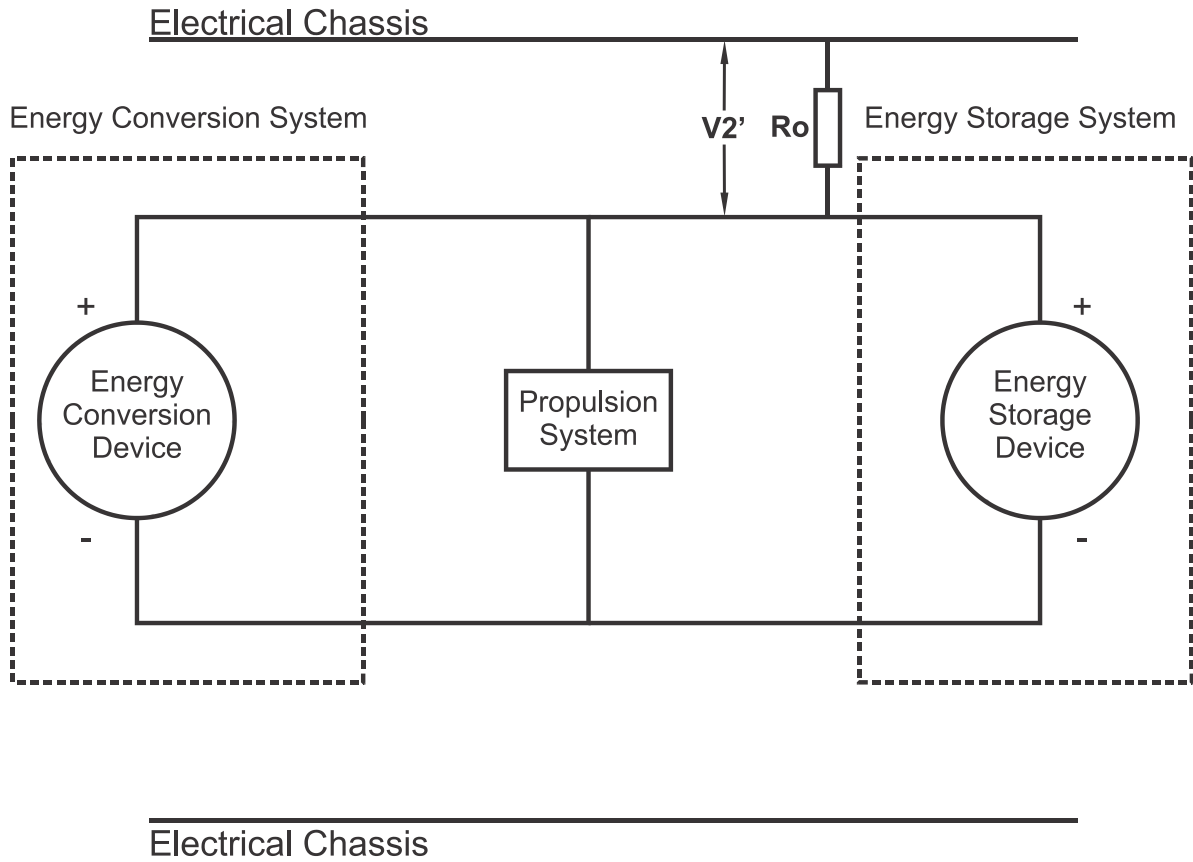

**Figure 4 — S7.6.6 Measurement for V1' Voltage across Resistor between Negative Side of the High Voltage Source and Electrical Chassis**



$$R_i = R_o (1 + V_2/V_1) ((V_1 - V_1')/V_1')$$

**Figure 5 — S7.6.7 Measurement for V2' Voltage across Resistor between Positive Side of High Voltage Source and Electrical Chassis**



$$R_i = R_o (1 + V_1/V_2) ((V_2 - V_2')/V_2')$$

**Figure 6 — Marking of High Voltage Equipment**

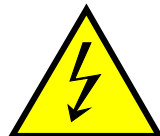

**Figure 7a — Access Probes for the Tests of Direct Contact Protection**

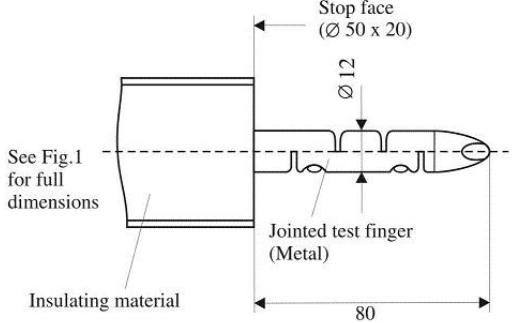
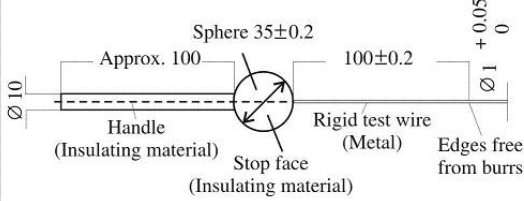
First numeral	Addit. letter	Access probe (Dimensions in mm)	Test force
2	B	<p style="text-align: center;"><b>Jointed test finger</b></p>  <p style="text-align: center;">Jointed test finger (Metal)</p>	10 N ± 10%
4, 5, 6	D	<p style="text-align: center;"><b>Test wire 1.0 mm diameter, 100 mm long</b></p>  <p style="text-align: center;">Rigid test wire (Metal)</p>	1N ± 10%



**Figure 8 — Connection to Determine Resistance between Physical Barrier and Electrical Chassis**

