



Transport
Canada

Transports
Canada

Motor
Vehicle
Safety

Sécurité des
véhicules
automobiles

Standards and Regulations Division

TECHNICAL STANDARDS DOCUMENT

No. 222, Revision 0

School Bus Passenger Seating and Crash Protection

The text of this document is based on Federal Motor Vehicle Safety Standard No. 222, SCHOOL BUS PASSENGER SEATING AND CRASH PROTECTION, as published in the U.S. *Code of Federal Regulations*, Title 49, Part 571, revised as of October 1, 2017.

Publication Date: July 11, 2018
Effective Date: July 11, 2018
Mandatory Compliance Date: September 1, 2020

Motor Vehicle Standards, Research and Development Branch
Road Safety and Motor Vehicle Regulation Directorate
TRANSPORT CANADA
Ottawa, Ontario
K1A 0N5

**Technical Standards Document
Number 222, Revision 0**

**SCHOOL BUS PASSENGER SEATING AND CRASH
PROTECTION**

(Ce document est aussi disponible en français.)

Introduction

As defined by section 12 of the *Motor Vehicle Safety Act*, a Technical Standards Document (TSD) is a document that reproduces an enactment of a foreign government (e.g. a Federal Motor Vehicle Safety Standard issued by the U.S. National Highway Traffic Safety Administration). According to the Act, the *Motor Vehicle Safety Regulations* may alter or override some provisions contained in a TSD or specify additional requirements; consequently, it is advisable to read a TSD in conjunction with the Act and its counterpart Regulation. As a guide, where the corresponding Regulation contains additional requirements, footnotes indicate the amending subsection number.

TSDs are revised from time to time in order to incorporate amendments made to the reference document, at which time a Notice of Revision is published in the *Canada Gazette*, Part I. All TSDs are assigned a revision number, with “Revision 0” designating the original version.

Identification of Changes

In order to facilitate the incorporation of a TSD, certain non-technical changes may be made to the foreign enactment. These may include the deletion of words, phrases, figures, or sections that do not apply under the Act or Regulations, the conversion of imperial to metric units, the deletion of superseded dates, and minor changes of an editorial nature. Additions are underlined, and provisions that do not apply are ~~stroked through~~. Where an entire section has been deleted, it is replaced by: “[CONTENT NOT REPRODUCED]”. Changes are also made where there is a reporting requirement or reference in the foreign enactment that does not apply in Canada. For example, the name and address of the United States Department of Transportation are replaced by those of the Department of Transport.

Effective Date and Mandatory Compliance Date

The effective date of a TSD is the date of publication of its incorporating regulation or of the notice of revision in the *Canada Gazette*, and the date as of which voluntary compliance is permitted. The mandatory compliance date is the date upon which compliance with the requirements of the TSD is obligatory. If the effective date and mandatory compliance date are different, manufacturers may follow the requirements that were in force before the effective date, or those of the TSD, until the mandatory compliance date.

In the case of an initial TSD, or when a TSD is revised and incorporated by reference by an amendment to the Regulations, the mandatory compliance date is as specified in the Regulations, and it may be the same as the effective date. When a TSD is revised with no corresponding changes to the incorporating Regulations, the mandatory compliance date is six months after the effective date.

Official Version of Technical Standards Documents

Technical Standards Documents may be consulted electronically in both HTML and Portable Document Format (PDF) on the Department of Transport's Web site at <http://www.tc.gc.ca/eng/acts-regulations/regulations-crc-c1038.htm>. The PDF version is a replica of the TSD as published by the Department and is to be used for the purposes of legal interpretation and application. The HTML version is provided for information purposes only.

(Original signed by)

Director, Motor Vehicle Standards,
Research and Development
for the Minister of Transport,
Ottawa, Ontario

TABLE OF CONTENTS

Technical Standards Document Number 222, Revision 0

SCHOOL BUS PASSENGER SEATING AND CRASH PROTECTION

Introduction	i
Identification of Changes	i
Effective Date and Mandatory Compliance Date	i
Official Version of Technical Standards Documents	ii
S1. Scope and purpose	1
S2. Purpose	1
S3. [CONTENT NOT REPRODUCED]	1
S4. Definitions	1
S4.1 Determination of the number of seating positions and seat belt positions	2
S5. Requirements	3
S5.1 <i>Seating requirements.</i> School bus passenger seats shall be forward facing.	4
S5.1.1 [Reserved]	4
S5.1.2 Seat back height, position, and surface area.	4
S5.1.3 Seat performance forward.	5
S5.1.4 Seat performance rearward.	5
S5.1.5 Seat cushion latching and retention.	6
S5.1.6 Quasi-static test of compartmentalization and Type 2 seat belt performance.	7
S5.1.7 Buckle side length limit.	10
S5.2 Restraining barrier requirements.	11
S5.2.1 Barrier-seat separation.	11
S5.2.2 Barrier height, position, and rear surface area.	11
S5.2.3 Barrier performance forward.	11
S5.3 Impact zone requirements.	11
S5.3.1 Head protection zone.	11
S5.3.2 Leg protection zone.	12
S5.4	12
S5.4.1 Wheelchair securement anchorages.	12
S5.4.2 Wheelchair securement devices.	13
S5.4.3 Wheelchair occupant restraint anchorages.	13
S5.4.4 Wheelchair occupant restraints.	14
S5.5 <i>Labeling.</i>	14
S6. Test conditions.	15
S6.1 Test surface.	15
S6.2 <i>Tires.</i>	15

S6.3	Temperature.	15
S6.4	Seat back position.	15
S6.5	Loading bar.	15
S6.5.1		15
S6.6	Head form.	15
S6.6.1		16
S6.6.2		16
S6.6.3		16
S6.7	Knee form.	16
S6.7.1		16
S6.7.2		16
S6.7.3		17
S6.8		17

**Technical Standards Document
Number 222, Revision 0**

**SCHOOL BUS PASSENGER SEATING AND CRASH
PROTECTION**

The text of this document is based on Federal Motor Vehicle Safety SCHOOL BUS PASSENGER SEATING AND CRASH PROTECTION, as published in the U.S. Code of Federal Regulations, Title 49, Part 571, revised as of XXXXXXXXXX.

S1. Scope and purpose

This standard establishes occupant protection requirements for school bus passenger seating and restraining barriers.

S2. Purpose

The purpose of this standard is to reduce the number of deaths and the severity of injuries that result from the impact of school bus occupants against structures within the vehicle during crashes and sudden driving maneuvers.

S3. [CONTENT NOT REPRODUCED]

S4. Definitions

Contactable surface means any surface within the zone specified in S5.3.1.1 that is contactable from any direction by the test device described in S6.6, except any surface on the front of a seat back or restraining barrier 76 mm or more below the top of the seat back or restraining barrier.

Fixed occupancy seat means a bench seat equipped with Type 2 seat belts that has a permanent configuration regarding the number of seating positions on the seat. The number of seating positions on the bench seat cannot be increased or decreased.

Flexible occupancy seat means a bench seat equipped with Type 2 seat belts that can be reconfigured so that the number of seating positions on the seat can change. The seat has a minimum occupancy configuration and maximum occupancy configuration, and the number of passengers capable of being carried in the minimum occupancy configuration must differ from the number of passengers capable of being carried in the maximum occupancy configuration.

Maximum occupancy configuration means, on a bench seat equipped with Type 2 seat belts, an arrangement whereby the lap belt portion of the Type 2 seat belts is such that the maximum number of occupants can be belted.

Minimum occupancy configuration means, on a bench seat equipped with Type 2 seat belts, an arrangement whereby the lap belt portion of the Type 2 seat belts is such that the minimum number of occupants can be belted.

School bus passenger seat means a seat in a school bus, other than the driver's seat.

Seat bench width means the maximum transverse width of the bench seat cushion.

Small occupant seating position means the center seating position on a flexible occupancy seat in a maximum occupancy configuration, if the torso belt portion of the Type 2 seat belt is intended to restrain occupants whose dimensions range from those of a 50th percentile 6 year-old child only to those of a 50th percentile 10 year-old child and the torso belt anchor point cannot achieve a minimum height of 520 mm above the seating reference point, as specified by S4.1.3.2(a) of TSD 21049 ~~CFR 571.210~~.

~~*Wheelchair* means a wheeled seat frame for the support and conveyance of a physically disabled person, comprised of at least a frame, seat, and wheels.~~

~~*Wheelchair occupant restraint anchorage* means the anchorage that transfers the provision for transferring wheelchair occupant restraint system loads to the vehicle structure.~~

~~*Wheelchair securement anchorage* means the provision for transferring wheelchair securement device loads to the vehicle structure.~~

~~*Wheelchair securement device* means a strap, webbing or other device used for securing a wheelchair to the school bus, including all necessary buckles and other fasteners.~~

S4.1 Determination of the number of seating positions and seat belt positions

- ~~(a) The number of seating positions considered to be in a bench seat for vehicles manufactured before October 21, 2011 is expressed by the symbol W, and calculated as the seat bench width in millimeters divided by 381 and rounded to the nearest whole number.~~
- ~~(b) The number of seating positions and the number of Type 1 seat belt positions considered to be in a bench seat for vehicles manufactured on or after October 21, 2011 is expressed by the symbol W, and calculated as the seat bench width in millimeters divided by 380 and rounded to the nearest whole number.~~
- ~~(c) Except as provided in S4.1(d), the number of Type 2 seat belt positions on a flexible occupancy seat in a minimum occupancy configuration or a fixed occupancy seat for vehicles manufactured on or after October 21, 2011 is expressed by the symbol Y, and calculated as the seat bench width in millimeters divided by 380 and rounded to the next~~

lowest whole number. The minimum seat bench width for a seat equipped with a Type 2 seat belt is 380 mm. See Table 1 for an illustration.

- (d) A flexible occupancy seat meeting the requirements of S4.1(c) may also have a maximum occupancy configuration with Y +1 Type 2 seat belt positions, if the minimum seat bench width for this configuration is Y +1 times 330 mm. See Table 1 for an illustration.
- (e) A flexible occupancy seat equipped with Type 2 seat belts in a maximum occupancy configuration may have up to one single small occupant seating position.

TABLE 1—NUMBER OF SEATING POSITIONS AS A FUNCTION OF SEAT BENCH WIDTH

Seating configuration	Seat bench width (mm)				
	380-659	660-759	760-989	990-1139	1140-1319
Minimum or Fixed Occupancy	1	1	2	2	3
Maximum Occupancy	1	2	2	3	3

S5. Requirements

(a) *Large school buses.*

- 1) Each school bus manufactured before October 21, 2011 with a gross vehicle weight rating of more than 4,536 kg (10,000 pounds) shall be capable of meeting any of the requirements set forth under this heading when tested under the conditions of S6. However, a particular school bus passenger seat (i.e., a test specimen) in that weight class need not meet further requirements after having met S5.1.2 and S5.1.5, or having been subjected to either S5.1.3, S5.1.4, or S5.3. (2) Each school bus manufactured on or after October 21, 2011 with a gross vehicle weight rating of more than 4,536 kg (10,000 pounds) shall be capable of meeting any of the requirements set forth under this heading when tested under the conditions of S6 of this standard or CMVSS 210§ 571.210. However, a particular school bus passenger seat (i.e., a test specimen) in that weight class need not meet further requirements after having met S5.1.2 and S5.1.5, or having been subjected to either S5.1.3, S5.1.4, S5.1.6 (if applicable), or S5.3. If S5.1.6.5.5(b) is applicable, a particular test specimen need only meet S5.1.6.5.5(b)(1) or (2) as part of meeting S5.1.6 in its entirety. Each vehicle with voluntarily installed Type 1 seat belts and seat belt anchorages at W seating positions in a bench seat, voluntarily installed Type 2 seat belts and seat belt anchorages at Y seat belt positions in a fixed occupancy seat, or voluntarily installed Type 2 seat belts and seat belt anchorages at Y and Y + 1 seat belt positions in a flexible occupancy seat, shall also meet the requirements of:
- (i) S4.4.3.2 of Standard No. 208 (49 CFR 571.208);
 - (ii) CMVSS 209Standard No. 209 (49 CFR 571.209), as they apply to school buses; and,
 - (iii)CMVSS 210Standard No. 210 (49 CFR 571.210) as it applies to school buses with a gross vehicle weight rating greater than 10,000 pounds.

- (b) *Small school buses.* Each vehicle with a gross vehicle weight rating of 4,536 kg (10,000 pounds) or less shall be capable of meeting the following requirements at all seating positions:
- 1) ~~In the case of vehicles manufactured before September 1, 1991, the requirements of §§ 571.208, 571.209, and 571.210 as they apply to multipurpose passenger vehicles;~~
 - (i) ~~[Reserved]~~
 - (ii) ~~In the case of vehicles manufactured on or after September 1, 1991, the requirements of S4.4.3.3 of § 571.208 and the requirements of §§ 571.209 and 571.210 as they apply to school buses with a gross vehicle weight rating of 4,536 kg or less~~(iii) ~~In the case of vehicles manufactured on or after October 21, 2011 the requirements of S4.4.3.2. of § 571.208 and the requirements of §§ 571.207, 571.209 and 571.210 as they apply to school buses with a gross vehicle weight rating of 4,536 kg or less; and,~~
 - 2) ~~The requirements of S5.1.2, S5.1.3, S5.1.4, S5.1.5, S5.1.6, S5.1.7, S5.3, S5.4 and S5.5 of this standard. However, the requirements of §§ 571.208 and 571.210 shall be met at Y seat belt positions in a fixed occupancy seat, and at Y and Y + 1 seat belt positions for a flexible occupancy seat. A particular school bus passenger seat (i.e. a test specimen) in that weight class need not meet further requirements after having met S5.1.2 and S5.1.5, or after having been subjected to either S5.1.3, S5.1.4, S5.1.6, or S5.3 of this standard or § 571.207, § 571.210 or § 571.225.~~

S5.1 *Seating requirements.* School bus passenger seats shall be forward facing.

S5.1.1 [Reserved]

S5.1.2 Seat back height, position, and surface area.

- (a) ~~For school buses manufactured before October 21, 2009, each school bus passenger seat must be equipped with a seat back that has a vertical height of at least 508 mm (20 inches) above the seating reference point. Each school bus passenger seat must be equipped with a seat back that, in the front projected view, has front surface area above the horizontal plane that passes through the seating reference point, and below the horizontal plane 508 mm (20 inches) above the seating reference point, of not less than 90 percent of the seat bench width in millimeters multiplied by 508.~~
- (b) ~~For school buses manufactured on or after October 21, 2009, Each school bus passenger seat must be equipped with a seat back that has a vertical height of at least 610 mm (24 inches) above the seating reference point. The minimum total width of the seat back at 610 mm (24 inches) above the seating reference point shall be 75 percent of the maximum width of the seat bench. Each school bus passenger seat must be equipped with a seat back that, in the front projected view, has front surface area above the horizontal plane that passes through the seating reference point, and below the horizontal plane 610 mm (24 inches) above the seating reference point, of not less than 90 percent of the seat bench width in millimeters multiplied by 610.~~

S5.1.3 Seat performance forward.

When a school bus passenger seat that has another seat behind it is subjected to the application of force as specified in S5.1.3.1 and S5.1.3.2, and subsequently, the application of additional force to the seat back as specified in S5.1.3.3 and S5.1.3.4:

- (a) The seat back force/deflection curve shall fall within the zone specified in Figure 1;
- (b) Seat back deflection shall not exceed 356 mm; (for determination of (a) and (b) the force/deflection curve describes only the force applied through the upper loading bar, and only the forward travel of the pivot attachment point of the upper loading bar, measured from the point at which the initial application of 44 N of force is attained.)
- (c) The seat shall not deflect by an amount such that any part of the seat moves to within 102 mm of any part of another school bus passenger seat or restraining barrier in its originally installed position;
- (d) The seat shall not separate from the vehicle at any attachment point; and
- (e) Seat components shall not separate at any attachment point.

S5.1.3.1 Position the loading bar specified in S6.5 so that it is laterally centered behind the seat back with the bar's longitudinal axis in a transverse plane of the vehicle and in any horizontal plane between 102 mm above and 102 mm below the seating reference point of the school bus passenger seat behind the test specimen.

S5.1.3.2 Apply a force of 3,114W newtons horizontally in the forward direction through the loading bar at the pivot attachment point. Reach the specified load in not less than 5 nor more than 30 seconds.

S5.1.3.3 No sooner than 1.0 second after attaining the required force, reduce that force to 1,557W newtons and, while maintaining the pivot point position of the first loading bar at the position where the 1,557W newtons is attained, position a second loading bar described in S6.5 so that it is laterally centered behind the seat back with the bar's longitudinal axis in a transverse plane of the vehicle and in the horizontal plane 406 mm above the seating reference point of the school bus passenger seat behind the test specimen, and move the bar forward against the seat back until a force of 44 N has been applied.

S5.1.3.4 Apply additional force horizontally in the forward direction through the upper bar until 452W joules of energy have been absorbed in deflecting the seat back (or restraining barrier). Apply the additional load in not less than 5 seconds nor more than 30 seconds. Maintain the pivot attachment point in the maximum forward travel position for not less than 5 seconds nor more than 10 seconds and release the load in not less than 5 nor more than 30 seconds. (For the determination of S5.1.3.4 the force/deflection curve describes only the force applied through the upper loading bar, and the forward and rearward travel distance of the upper loading bar pivot attachment point measured from the position at which the initial application of 44 N of force is attained.)

S5.1.4 Seat performance rearward.

When a school bus passenger seat that has another seat behind it is subjected to the application of force as specified in S5.1.4.1 and S5.1.4.2:

- (a) Seat back force shall not exceed 9,786 N;
- (b) Seat back deflection shall not exceed 254 mm; (for determination of (a) and (b) the force/deflection curve describes only the force applied through the loading bar, and only the rearward travel of the pivot attachment point of the loading bar, measured from the point at which the initial application of 222 N is attained.
- (c) The seat shall not deflect by an amount such that any part of the seat moves to within 102 mm of any part of another passenger seat in its originally installed position;
- (d) The seat shall not separate from the vehicle at any attachment point; and
- (e) Seat components shall not separate at any attachment point.

S5.1.4.1 Position the loading bar described in S6.5 so that it is laterally centered forward of the seat back with the bar's longitudinal axis in a transverse plane of the vehicle and in the horizontal plane 343 mm above the seating reference point of the test specimen, and move the loading bar rearward against the seat back until a force of 222 N has been applied.

S5.1.4.2 Apply additional force horizontally rearward through the loading bar until 316W joules (J) of energy has been absorbed in deflecting the seat back. Apply the additional load in not less than 5 seconds nor more than 30 seconds. Maintain the pivot attachment point in the maximum rearward travel position for not less than 5 seconds nor more than 10 seconds and release the load in not less than 5 seconds nor more than 30 seconds. (For determination of S5.1.4.2 the force deflection curve describes the force applied through the loading bar and the rearward and forward travel distance of the loading bar pivot attachment point measured from the position at which the initial application of 222 N of force is attained.)

S5.1.5 Seat cushion latching and retention.

- (a) School bus passenger seat cushions equipped with attachment devices that allow for the seat cushion to be removable without tools or to flip up must have a self-latching mechanism that latches when subjected to the conditions specified in S5.1.5.1. The seat cushion shall not separate from the seat at any attachment point when subjected to the conditions specified in S5.1.5.2 after being subjected to the conditions of S5.1.5.1.
- (b) School bus passenger seat cushions that are removable only with the use of tools shall not separate from the seat at any attachment point when subjected to the conditions of S5.1.5.2.

S5.1.5.1 Release the seat cushion self-latching mechanism. Lift the seat cushion then place the seat cushion back in the down position without activating the self-latching mechanism, if possible. Apply a downward force of 216 N (48.4 pounds) to the center of the seat cushion. The downward force shall be applied in any period of not less than 1 and not more than 5 seconds, and maintained for 5 seconds.

S5.1.5.2 Apply an upward force of 5 times the weight of the seat cushion to the center of the bottom of the seat cushion. The upward force shall be applied in any period of not less than 1 and not more than 5 seconds, and maintained for 5 seconds.

S5.1.6 Quasi-static test of compartmentalization and Type 2 seat belt performance. This section applies to school buses manufactured on or after October 21, 2011 with a gross vehicle weight rating expressed in the first column of Tables 2 through 4, and that are equipped with Type 2 seat belt assemblies.

- (a) Except as provided in S5.1.6(b), when tested under the conditions of S5.1.6.5.1 through S5.1.6.5.6, the criteria specified in S5.1.6.1 and S5.1.6.2 must be met.
- (b) A school bus passenger seat that does not have another seat behind it is not loaded with the upper and lower loading bars as specified in S5.1.6.5.2, S5.1.6.5.3, and S5.1.6.5.7 and is excluded from the requirements of S5.1.6.1(b).

S5.1.6.1 *Displacement limits.* In Tables 2 and 3, AH is the height in millimeters of the school bus torso belt anchor point specified by S4.1.3.2(a) of Standard No. 210 (49 CFR 571.210) and Φ is the angle of the posterior surface of the seat back defined in S5.1.6.3 of this standard.

- (a) Any school bus torso belt anchor point, as defined in S3 of Standard No. 210, must not displace horizontally forward from its initial position (when Φ was determined) more than the value in millimeters calculated from the following expression in the second column of Table 2:

TABLE 2—TORSO BELT ANCHOR POINT DISPLACEMENT LIMIT

Gross vehicle weight rating	Displacement limit in millimeters
More than 4,536 kg (10,000 pounds)	$(AH + 100) (\tan\Phi + 0.242/\cos\Phi)$
Less than or equal to 4,536 kg (10,000 pounds)	$(AH + 100) (\tan\Phi + 0.356/\cos\Phi)$

- (b) A point directly rearward of any school bus torso belt anchor point, as defined in S3 of Standard No. 210 (49 CFR 571.210) on the rear facing surface of the seat back, must not displace horizontally forward from its initial position (when Φ was determined) more than the value in millimeters calculated from the following expression in the second column of Table 3:

TABLE 3—SEAT BACK POINT DISPLACEMENT LIMIT

Gross vehicle weight rating	Displacement limit in millimeters
More than 4,536 kg (10,000 pounds)	$(AH + 100) (\tan\Phi + 0.174/\cos\Phi)$
Less than or equal to 4,536 kg (10,000 pounds)	$(AH + 100) (\tan\Phi + 0.259/\cos\Phi)$

S5.1.6.2 *Slippage of device used to achieve torso belt adjusted height.* If the torso belt adjusted height, as defined in S3 of ~~TSD 210~~ Standard No. 210 (49 CFR 571.210), is achieved without the use of an adjustable torso belt anchorage, the adjustment device must

not slip more than 25 mm (1.0 inches) along the webbing or guide material upon which it moves for the purpose of adjusting the torso belt height.

S5.1.6.3 Angle of the posterior surface of a seat back. If the seat back inclination is adjustable, the seat back is placed in the manufacturer's normal design riding position. If such a position is not specified, the seat back is positioned so it is in the most upright position. Position the loading bar specified in S6.5 of this standard so that it is laterally centered behind the seat back with the bar's longitudinal axis in a transverse plane of the vehicle in a horizontal plane within ± 6 mm (0.25 inches) of the horizontal plane passing through the seating reference point and move the bar forward against the seat back until a force of 44 N (10 pounds) has been applied. Position a second loading bar as described in S6.5 of this standard so that it is laterally centered behind the seat back with the bar's longitudinal axis in a transverse plane of the vehicle and in the horizontal plane 406 ± 6 mm (16 ± 0.25 inches) above the seating reference point, and move the bar forward against the seat back until a force of 44 N (10 pounds) has been applied. Determine the angle from vertical of a line in the longitudinal vehicle plane that passes through the geometric center of the cross-section of each cylinder, as shown in Figure 8. That angle is the angle of the posterior surface of the seat back.

S5.1.6.4 The seat back must absorb 452W joules of energy when subjected to the force specified in S5.1.6.5.7.

S5.1.6.5 Quasi-static test procedure.

S5.1.6.5.1 Adjust the seat back as specified in S5.1.6.3. Place all torso anchor points in their highest position of adjustment. If the torso belt adjusted height, as defined in S3 TSD 210 of FMVSS No. 210, is achieved by a method other than an adjustable anchor point, initially place the torso belt adjusted height at its highest position. Then move the adjustment device 38 mm (1.5 inches) downward with respect to its webbing or guide material.

S5.1.6.5.2 Position the lower loading bar specified in S6.5 of this standard so that it is laterally centered behind the seat back with the bar's longitudinal axis in a transverse plane of the vehicle and in any horizontal plane between 102 mm (4 inches) above and 102 mm (4 inches) below the seating reference point of the school bus passenger seat behind the test specimen. Position the upper loading bar described in S6.5 so that it is laterally centered behind the seat back with the bar's longitudinal axis in a transverse plane of the vehicle and in the horizontal plane 406 mm (16 inches) above the seating reference point of the school bus passenger seat behind the test specimen.

S5.1.6.5.3 Apply a force of 3,114W N (700W pounds) horizontally in the forward direction through the lower loading bar specified at S6.5 at the pivot attachment point. Reach the specified load in not less than 5 and not more than 30 seconds. No sooner than 1.0 second after attaining the required force, reduce that force to 1,557W N (350W pounds) and maintain the pivot point position of the loading bar at the position where the 1,557W N (350W pounds) is attained until the completion of S5.1.6.5.7 of this standard.

S5.1.6.5.4 Position the body block specified in Figure 3 of TSD 210 ~~FMVSS No. 210 (49 CFR 571.210)~~ under each torso belt (between the torso belt and the seat back) in the passenger seat and apply a preload force of 600 ± 50 N (135 ± 11 pounds) on each body block in a forward direction parallel to the longitudinal centerline of the vehicle pursuant to the specifications of TSD 210 ~~Standard No. 210 (49 CFR 571.210)~~. After preload application is complete, the origin of the 203 mm body block radius at any point across the 102 mm body block thickness shall lie within the zone defined by S5.1.6.5.4(a) and S5.1.6.5.4(b) as shown in Figure 9:

- (a) At or rearward of a transverse vertical plane of the vehicle located 100 mm longitudinally forward of the seating reference point.
- (b) Within 75 mm of the horizontal plane located midway between the horizontal plane passing through the school bus torso belt adjusted height, specified in S3 of TSD 210 ~~Standard No. 210 (49 CFR 571.210)~~, and the horizontal plane 100 mm below the seating reference point.

S5.1.6.5.5 *Load application* .

- (a) *Fixed Occupancy Seat*. For school buses with the gross vehicle weight rating listed in the first column of Table 4, if the expression in the second column is true, simultaneously apply the force listed in the third column to each body block.

TABLE 4—TORSO BODY BLOCK FORCES FOR FIXED OCCUPANCY SEATS

Gross vehicle weight rating	True expression	Applied force
More than 4,536 kg (10,000 pounds)	$((\text{seat bench width in mm}) - (380Y)) \leq 25 \text{ mm (1 inch)}$	3,300 N (742 pounds).
More than 4,536 kg (10,000 pounds)	$((\text{seat bench width in mm}) - (380Y)) > 25 \text{ mm (1 inch)}$	5,000 N (1,124 pounds).
Less than or equal to 4,536 kg (10,000 pounds)	$((\text{seat bench width in mm}) - (380Y)) \leq 25 \text{ mm (1 inch)}$	5,000 N (1,124 pounds).
Less than or equal to 4,536 kg (10,000 pounds)	$((\text{seat bench width in mm}) - (380Y)) > 25 \text{ mm (1 inch)}$	7,500 N (1,686 pounds).

- (b) *Flexible Occupancy Seat*.

- (i) For school buses with the gross vehicle weight rating listed in the first column of Table 5 and a bench seat in the maximum occupancy configuration for a flexible occupancy seat of Y+1 seat belt positions as specified in S4.1(d), simultaneously apply the force listed in the second column of Table 5 to each body block.

TABLE 5—TORSO BODY BLOCK FORCES IN MAXIMUM OCCUPANCY CONFIGURATION

Gross vehicle weight rating	Applied force
More than 4,536 kg (10,000 pounds)	3,300 N (742 pounds).
Less than or equal to 4,536 kg (10,000 pounds)	5,000 N (1,124 pounds).

- (ii) For a flexible occupancy seat in the minimum occupant configuration, apply the forces to each body block as specified in S5.1.6.5.5(a).

S5.1.6.5.6 Reach the specified load in not less than 5 and not more than 30 seconds. While maintaining the load, measure the school bus torso belt anchor point and seat back point horizontal displacement and then remove the body block.

S5.1.6.5.7 Move the upper bar forward against the seat back until a force of 44 N has been applied. Apply an additional force horizontally in the forward direction through the upper bar until 452W joules of energy have been absorbed in deflecting the seat back. The maximum travel of the pivot attachment point for the upper loading bar shall not exceed 356 mm as measured from the position at which the initial application of 44 N of force is attained and the maximum load must stay below the upper boundary of the force/deflection zone in Figure 1. Apply the additional load in not less than 5 seconds and not more than 30 seconds. Maintain the pivot attachment point at the maximum forward travel position for not less than 5 seconds, and not more than 10 seconds and release the load in not less than 5 seconds and not more than 30 seconds. (For the determination of S5.1.6.5.7, the energy calculation describes only the force applied through the upper loading bar, and the forward and rearward travel distance of the upper loading bar pivot attachment point measured from the position at which the application in this section of 44 N of force is attained.)

S5.1.7 Buckle side length limit.

This section applies to rear passenger seats on school buses ~~manufactured on or after October 21, 2014~~ that are equipped with ~~Type 1 or~~ Type 2 seat belt assemblies. All portions of the buckle/latchplate assembly must remain rearward of the limit plane defined in S5.1.7.1 when tested under the conditions of S5.1.7.2.

S5.1.7.1 *Buckle/latchplate limit plane.* Establish a transverse limit plane 65 mm from the SgRP that is perpendicular to a transverse plane that passes through the SgRP at an angle of 50 degrees to the horizontal.

S5.1.7.2 *Load application.* Insert the seat belt latchplate into the seat belt buckle. Apply a 20 N load to the buckle/latchplate assembly whose vector is in a vertical longitudinal plane. Apply the load along the centerline of the webbing attached to the latchplate at least 100mm from the nearest point on the latchplate. The load may be applied at any angle in the range of 30 to 75 degrees from horizontal.

S5.2 Restraining barrier requirements.

Each vehicle shall be equipped with a restraining barrier forward of any designated seating position that does not have the rear surface of another school bus passenger seat within 610 mm of its seating reference point, measured along a horizontal longitudinal line through the seating reference point in the forward direction.

S5.2.1 Barrier-seat separation.

The horizontal distance between the restraining barrier's rear surface and the seating reference point of the seat in front of which the barrier is required shall not be more than 610 mm measured along a horizontal longitudinal line through the seating reference point in the forward direction.

S5.2.2 Barrier height, position, and rear surface area.

The position and rear surface area of the restraining barrier shall be such that, in a front projected view of the bus, each point of the barrier's perimeter coincides with or lies outside of the perimeter of the minimum seat back area required by S5.1.2 for the seat immediately rearward of the restraining barrier.

S5.2.3 Barrier performance forward.

When force is applied to the restraining barrier in the same manner as specified in S5.1.3.1 through S5.1.3.4 for seating performance tests:

- (a) The restraining barrier force/deflection curve shall fall within the zone specified in Figure 1;
- (b) Restraining barrier deflection shall not exceed 356 mm; (for computation of (a) and (b) the force/deflection curve describes only the force applied through the upper loading bar, and only the forward travel of the pivot attachment point of the loading bar, measured from the point at which the initial application of 44 N of force is attained.)
- (c) Restraining barrier deflection shall not interfere with normal door operation;
- (d) The restraining barrier shall not separate from the vehicle at any attachment point; and
- (e) Restraining barrier components shall not separate at any attachment point.

S5.3 Impact zone requirements.

S5.3.1 Head protection zone.

Any contactable surface of the vehicle within any zone specified in S5.3.1.1 shall meet the requirements of S5.3.1.2 and S5.3.1.3. However, a surface area that has been contacted pursuant to an impact test need not meet further requirements contained in S5.3.

S5.3.1.1 The head protection zones in each vehicle are the spaces in front of each school bus passenger seat which are not occupied by bus sidewall, window, or door structure and which, in relation to that seat and its seating reference point, are enclosed by the following planes;

- (a) Horizontal planes 305 mm and 1016 mm above the seating reference point;

- (b) A vertical longitudinal plane tangent to the inboard (aisle side) edge of the seat; and
- (c) A vertical longitudinal plane 83 mm inboard of the outboard edge of the seat;
- (d) Vertical transverse planes through and 762 mm forward of the reference point.

S5.3.1.2 *Head form impact requirement.* When any contactable surface of the vehicle within the zones specified in S5.3.1.1 is impacted from any direction at 6.7 m/s by the head form described in S6.6, the axial acceleration at the center of gravity of the head form shall be such that the expression

$$\left[\frac{1}{t_1 - t_2} \int_{t_1}^{t_2} a dt \right]^{2.5} (t_1 - t_2)$$

shall not exceed 1,000 where “a” is the axial acceleration expressed as a multiple of “g” (the acceleration due to gravity), and “t₁” and “t₂” are any two points in time during the impact.

S5.3.1.3 *Head form force distribution.* When any contactable surface of the vehicle within the zones specified in S5.3.1.1 is impacted from any direction at 6.7 m/s by the head form described in S6.6, the energy necessary to deflect the impacted material shall be not less than 4.5 joules before the force level on the head form exceeds 667 N. When any contactable surface within such zones is impacted by the head form from any direction at 1.5 m/s the contact area on the head form surface shall be not less than 1,935 mm².

S5.3.2 Leg protection zone.

Any part of the seat backs or restraining barriers in the vehicle within any zone specified in S5.3.2.1 shall meet the requirements of S5.3.2.2.

S5.3.2.1 The leg protection zones of each vehicle are those parts of the school bus passenger seat backs and restraining barriers bounded by horizontal planes 305 mm above and 102 mm below the seating reference point of the school bus passenger seat immediately behind the seat back or restraining barrier.

S5.3.2.2 When any point on the rear surface of that part of a seat back or restraining barrier within any zone specified in S5.3.2.1 is impacted from any direction at 4.9 m/s by the knee form specified in S6.7, the resisting force of the impacted material shall not exceed 2,669 N and the contact area on the knee form surface shall not be less than 1,935 mm².

S5.4

Each school bus having one or more locations designed for carrying a person seated in a wheelchair shall comply with S5.4.1 through S5.4.4 at each such wheelchair location.

S5.4.1 Wheelchair securement anchorages.

Each wheelchair location shall have not less than four wheelchair securement anchorages complying with S5.4.1.1 through S5.4.1.3.

S5.4.1.1 Each wheelchair securement anchorage shall have a wheelchair securement device complying with S5.4.2 attached to it.

S5.4.1.2 The wheelchair securement anchorages at each wheelchair location shall be situated so that—

- (a) A wheelchair can be secured in a forward-facing position.
- (b) The wheelchair can be secured by wheelchair securement devices at two locations in the front and two locations in the rear.
- (c) The front wheel of a three-wheeled wheelchair can be secured.

S5.4.1.3 Each wheelchair securement anchorage shall be capable of withstanding a force of 13,344 Newtons applied as specified in paragraphs (a) through (d) of this section. When more than one securement device share a common anchorage, the anchorage shall be capable of withstanding a force of 13,344 Newtons multiplied by the number of securement devices sharing that anchorage.

- (a) The initial application force shall be applied at an angle of not less than 30 degrees, but not more than 60 degrees, measured from the horizontal. (See Figure 4.)
- (b) The horizontal projection of the force direction shall be within a horizontal arc of ± 45 degrees relative to a longitudinal line which has its origin at the anchorage location and projects rearward for an anchorage whose wheelchair securement device is intended to secure the front of the wheelchair and forward for an anchorage whose wheelchair securement device is intended to secure the rear of the wheelchair. (See Figure 4.)
- (c) The force shall be applied at the onset rate of not more than 133,440 Newtons per second.
- (d) The 13,344 Newton force shall be attained in not more than 30 seconds, and shall be maintained for 10 seconds.

S5.4.2 Wheelchair securement devices.
Each wheelchair securement device shall—

- (a) If incorporating webbing or a strap—
 - (i) Comply with the requirements for Type 1 safety belt systems in S4.2, S4.3, and S4.4(a) of ~~TSD 209 FMVSS No. 209, *Seat Belt Assemblies*~~; and
 - (ii) Provide a means of adjustment to remove slack from the device.
- (b) If not incorporating webbing or a strap, limit movement of the wheelchair through either the equipment design or a means of adjustment.

S5.4.3 Wheelchair occupant restraint anchorages.

S5.4.3.1 Each wheelchair location shall have:

- (a) Not less than one anchorage for the upper end of the upper torso restraint; and
- (b) Not less than two floor anchorages for wheelchair occupant pelvic and upper torso restraint.

S5.4.3.2 Each wheelchair occupant restraint floor anchorage shall be capable of withstanding a force of 13,344 Newtons applied as specified in paragraphs (a) through (d). When more than one wheelchair occupant restraint share a common anchorage, the anchorage shall be capable of withstanding a force of 13,344 Newtons multiplied by the number of occupant restraints sharing that anchorage.

- (a) The initial application force shall be applied at an angle of not less than 45 degrees, but not more than 80 degrees, measured from the horizontal. (See Figure 5.)
- (b) The horizontal projection of the force direction shall be within a horizontal arc of ± 45 degrees relative to a longitudinal line which has its origin at the anchorage and projects forward. (See Figure 5.)
- (c) The force shall be applied at an onset rate of not more than 133,440 Newtons per second.
- (d) The 13,344 Newton force shall be attained in not more than 30 seconds, and shall be maintained for 10 seconds.
- (e) When a wheelchair securement device and an occupant restraint share a common anchorage, including occupant restraint designs that attach the occupant restraint to the securement device or the wheelchair, the loads specified by S5.4.1.3 and S5.4.3.2 shall be applied simultaneously, under the conditions specified in S5.4.3.2 (a) and (b). (See Figure 6.)

S5.4.3.3 Each anchorage for a wheelchair occupant upper torso restraint shall be capable of withstanding a force of 6,672 Newtons applied as specified in paragraphs (a) through (d).

- (a) The initial application force shall be applied at a vertical angle of not less than zero degrees, but not more than 40 degrees, below a horizontal plane which passes through the anchorage. (See Figure 7.)
- (b) The projection of the force direction onto the horizontal plane shall be within zero degrees and 45 degrees as measured from a longitudinal line with its origin at the anchorage and projecting forward. (See Figure 7.)
- (c) The force shall be applied at the onset rate of not more than 66,720 Newtons per second.
- (d) The 6,672 Newton force shall be attained in not more than 30 seconds, and shall be maintained for 10 seconds.

S5.4.4 Wheelchair occupant restraints.

- (a) Each wheelchair location shall have wheelchair occupant pelvic and upper torso restraints attached to the anchorages required by S5.4.3.
- (b) Each wheelchair occupant restraint shall comply with the requirements for Type 2 safety belt systems in S4.2, S4.3, and S4.4(b) of CMVSS 209~~FMVSS No. 209~~, *Seat Belt Assemblies*.

S5.5 *Labeling*.

- (a) A small occupant seating position must be permanently and legibly marked or labeled with the phrases: “Do Not Sit In Middle Seat If Over Age 10” and “Le siège du milieu est interdit aux enfants de plus de 10 ans”. The phrases must be comprised of no more

than two lines of text. The label must be placed on the torso belt portion of the Type 2 seat belt. It must be plainly visible and easily readable when the seat belt is in a stored position. The distance from the top edge of the top line of text to the bottom edge of the bottom line of text must be at least 35 mm. If the label is sewn on, it must be stitched around its entire perimeter.

(b) [Reserved]

S6. Test conditions.

The following conditions apply to the requirements specified in S5.

S6.1 Test surface.

The bus is at rest on a level surface.

S6.2 *Tires.*

Tires are inflated to the pressure specified by the manufacturer for the gross vehicle weight rating.

S6.3 Temperature.

The ambient temperature is any level between 0 degrees C and 32 degrees C.

S6.4 Seat back position.

If adjustable, a seat back is adjusted to its most upright position.

S6.5 Loading bar.

The loading bar is a rigid cylinder with an outside diameter of 152 mm that has hemispherical ends with radii of 76 mm and with a surface roughness that does not exceed 1.6 μm , root mean square. The length of the loading bar is 102 mm less than the width of the seat back in each test. The stroking mechanism applies force through a pivot attachment at the center point of the loading bar which allows the loading bar to rotate in a horizontal plane 30 degrees in either direction from the transverse position.

S6.5.1

A vertical or lateral force of 17,792 N applied externally through the pivot attachment point of the loading bar at any position reached during a test specified in this standard shall not deflect that point more than 25 mm.

S6.6 Head form.

The head form for the measurement of acceleration is a rigid surface comprised of two hemispherical shapes, with total equivalent mass of 5.2 kg. The first of the two hemispherical

shapes has a diameter of 166 mm. The second of the two hemispherical shapes has a 50 mm diameter and is centered as shown in Figure 3 to protrude from the outer surface of the first hemispherical shape. The surface roughness of the hemispherical shapes does not exceed 1.6 μm , root mean square.

S6.6.1

The direction of travel of the head form is coincidental with the straight line connecting the centerpoints of the two spherical outer surfaces which constitute the head form shape.

S6.6.2

The head form is instrumented with an acceleration sensing device whose output is recorded in a data channel that conforms to the requirements for a 1,000 Hz channel class as specified in SAE Recommended Practice J211a (1971) (~~incorporated by reference~~, see the list at Chapter V, Title 49, part 571.5 paragraph (k) of the *Code of Federal Regulations* for the full citation, hereafter Chapter V, Title 49, part 571.5 of the *Code of Federal Regulations* is referred to as 49 CFR Part§ 571.5). The head form exhibits no resonant frequency below three times the frequency of the channel class. The axis of the acceleration sensing device coincides with the straight line connecting the centerpoints of the two hemispherical outer surfaces which constitute the head form shape.

S6.6.3

The head form is guided by a stroking device so that the direction of travel of the head form is not affected by impact with the surface being tested at the levels called for in the standard.

S6.7 Knee form.

The knee form for measurement of force is a rigid 76 millimeter-diameter cylinder, with an equivalent weight of 44 N that has one hemispherical end with a 38 mm radius forming a contact surface of the knee form. The hemispherical surface roughness does not exceed 1.6 μm , root mean square.

S6.7.1

The direction of travel of the knee form is coincidental with the centerline of the rigid cylinder.

S6.7.2

The knee form is instrumented with an acceleration sensing device whose output is recorded in a data channel that conforms to the requirements of a 600 Hz channel class as specified in SAE Recommended Practice J211a (1971) (, see the list at 49 CFR Part§ 571.5paragraph (k) for the full citation). The knee form exhibits no resonant frequency below three times the frequency of the channel class. The axis of the acceleration sensing device is aligned to measure acceleration along the centerline of the cylindrical knee form.

S6.7.3

The knee form is guided by a stroking device so that the direction of travel of the knee form is not affected by impact with the surface being tested at the levels called for in the standard.

S6.8

The head form, knee form, and contactable surfaces are clean and dry during impact testing.

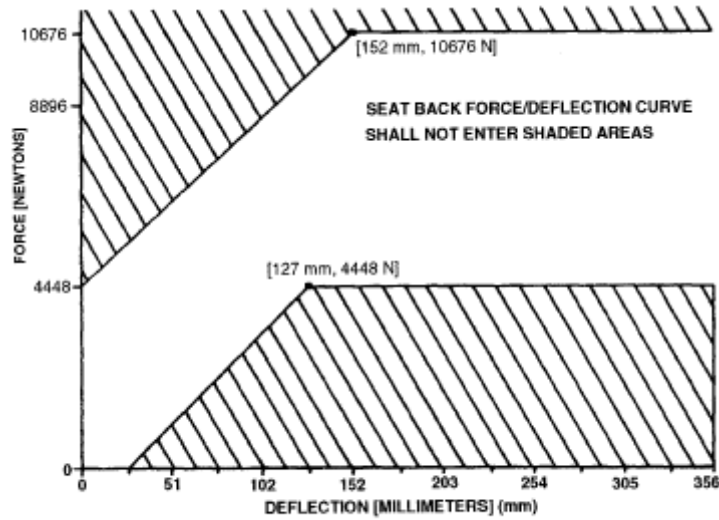

Figure 1.—Force/Deflection Zone

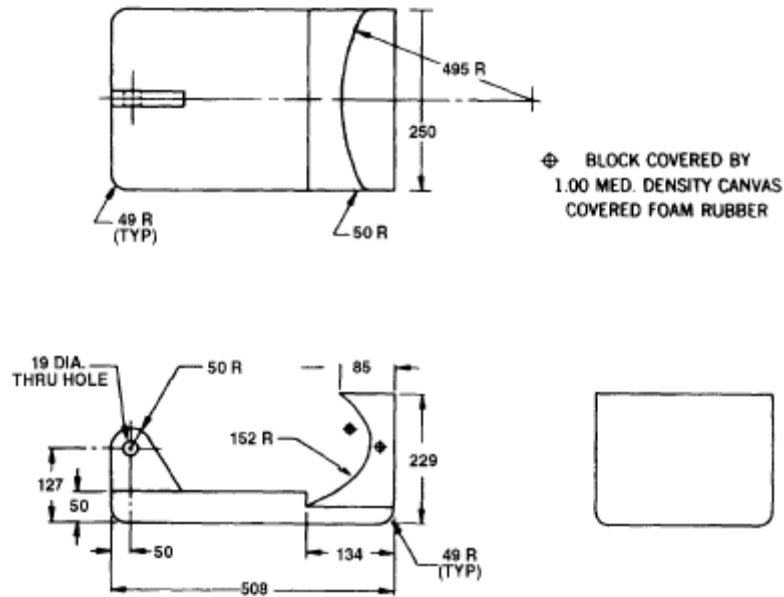

Figure 2.—Body Block for Lap Belt
All Dimensions in Millimeters (mm)

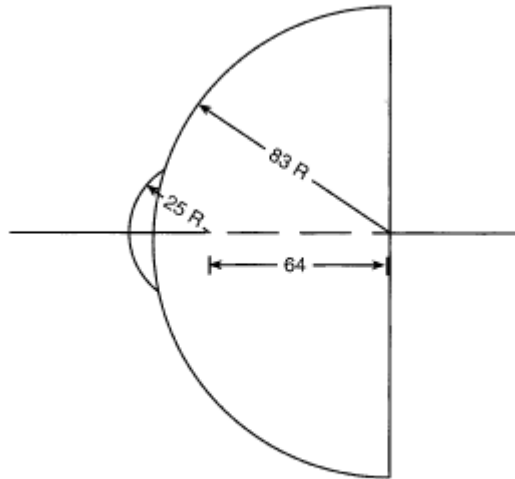

Figure 3
All dimensions in millimeters (mm)

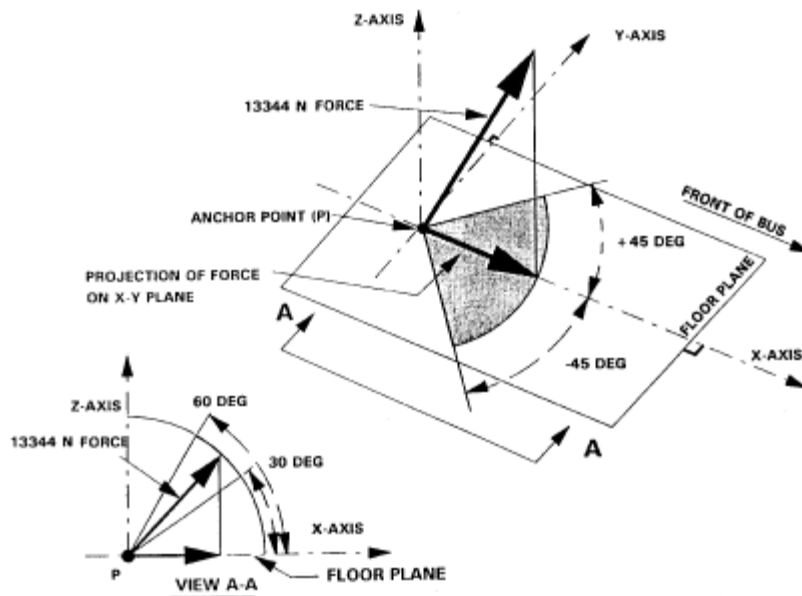

Figure 4. Wheelchair Securement Anchorage Loading Direction (Rear Anchorage Shown)

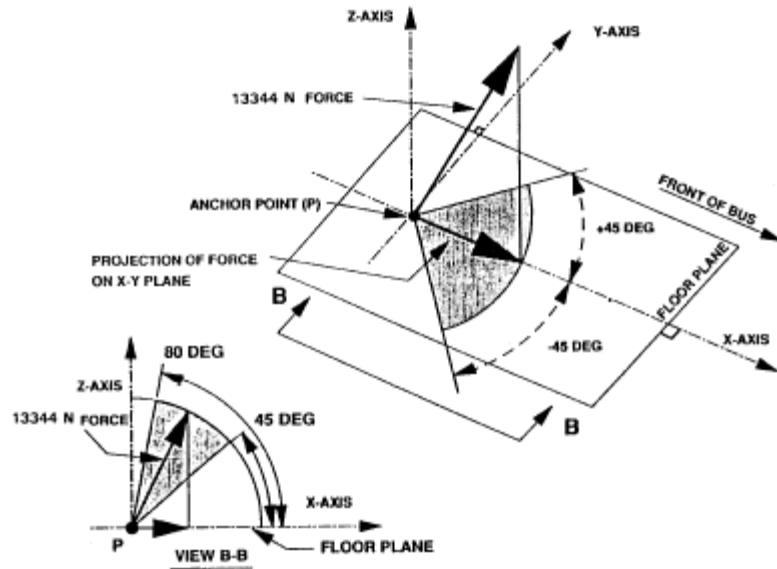

Figure 5. Pelvic Restraint Anchorage Loading Direction

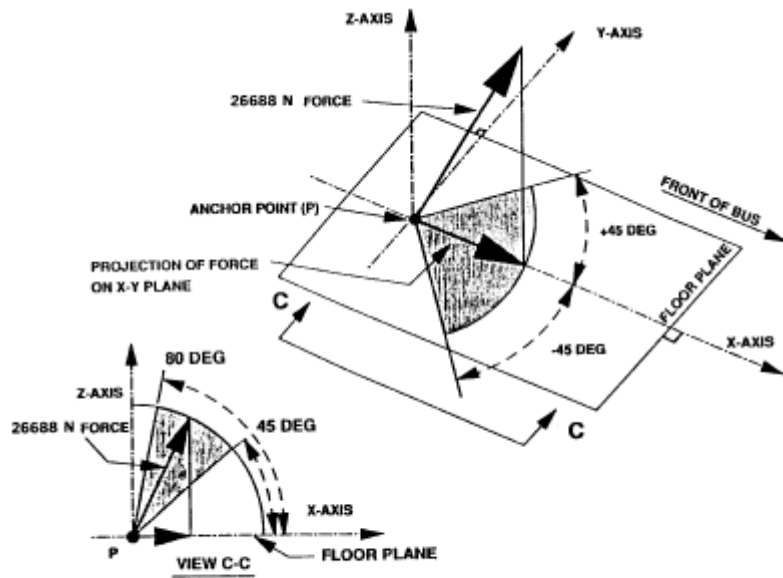

Figure 6. Pelvic Restraint and Wheelchair Securement Common Anchorage Loading Direction (Rear Direction Only)

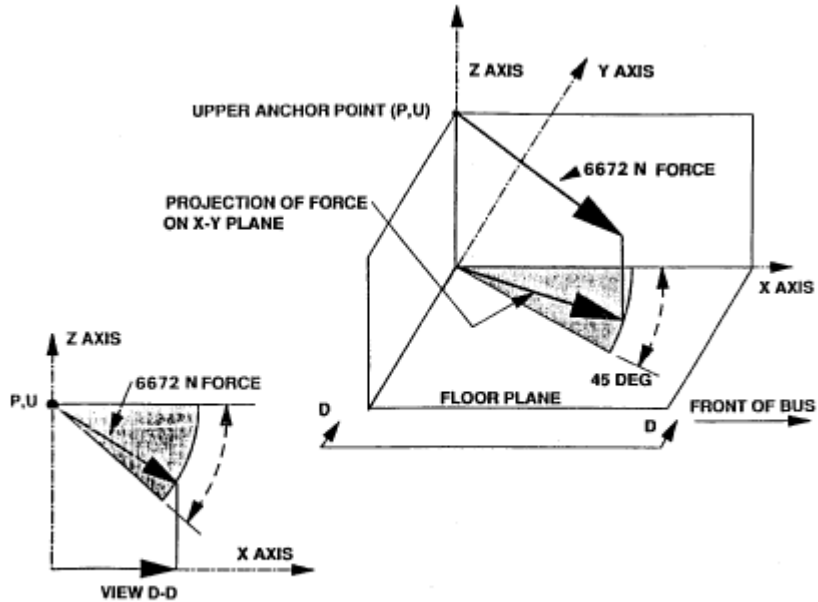

Figure 7. Upper Torso Restraint and Torso Harness Anchorage Loading Location

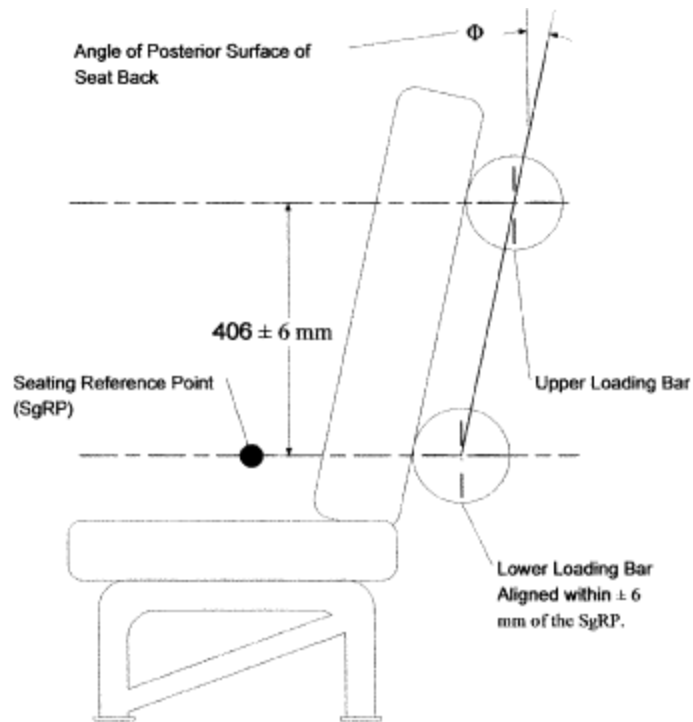

Figure 8 – Definition of initial angle of compartmentalizing seat back surface

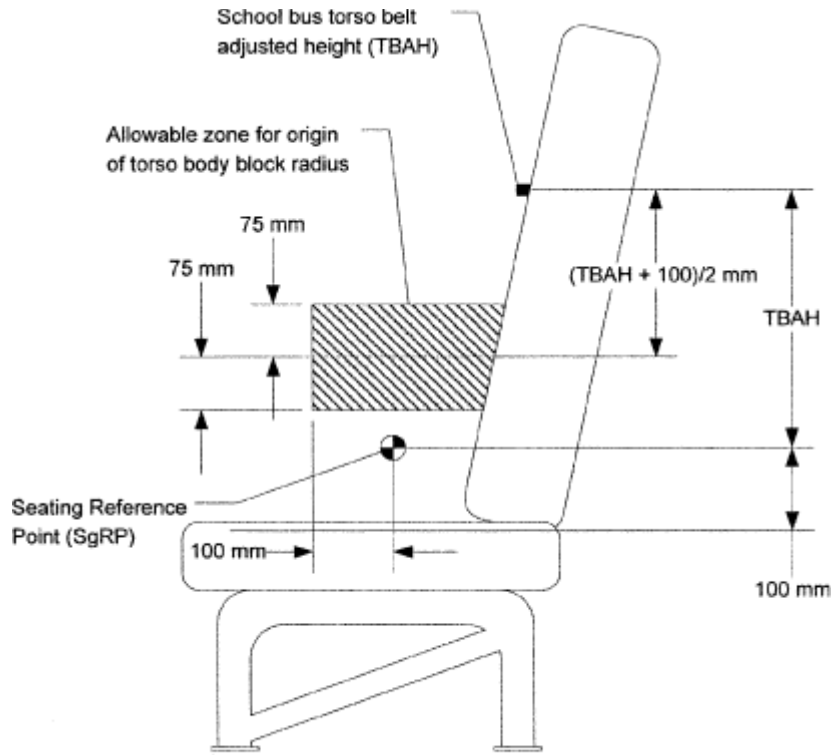

Figure 9 – Torso Block Zone